

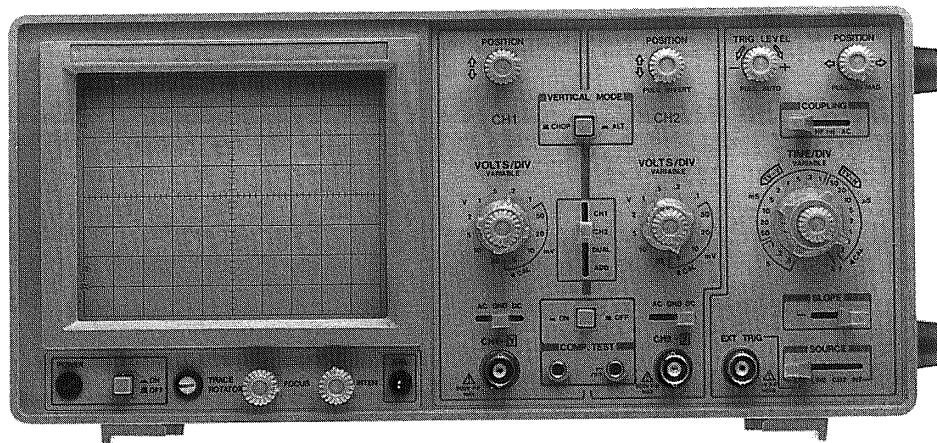

# ISOTECH

## Model ISR420

### 20 MHz DUAL TRACE OSCILLOSCOPE



### OPERATORS INSTRUCTION MANUAL



## TABLE OF CONTENTS

SECTION 1	INTRODUCTION .....	Page 1
SECTION 2	SPECIFICATION .....	1
SECTION 3	OPERATION .....	2
3-1	INITIAL OPERATION .....	3
3-2	CONTROLS & INDICATION .....	5
3-3	TRIGGERING .....	6
3-4	X-Y OPERATION .....	6
3-5	CALIBRATED VOLTAGE MEASUREMENTS .....	6
3-6	DUAL TRALE WAVEFORM OBSERVATION .....	6
3-7	TV SIGNAL SYNCHRONIZATION .....	7
3-8	ADD & SUB MEASUREMENTS .....	7
3-9	APPLICATIONS .....	7
3-9-(1)	AC Voltage and Frequency Measurement .....	8
3-9-(2)	DC Voltage Measurement .....	8
3-9-(3)	AM Modulation Measurement .....	8
3-9-(4)	Dual-Trace Application .....	8
3-9-(5)	Level Comparison .....	8
3-9-(6)	Repairing Stereo Systems .....	8
3-9-(7)	TV Servicing .....	9
3-9-(8)	Composite Video Analysis .....	9
3-9-(9)	Measurement of Frequency by X-Y .....	9
3-9-(10)	Phase Measurement .....	9
3-9-(11)	Photograph .....	9
3-9-(12)	Component Test .....	10
SECTION 4	CIRCUIT DESCRIPTION .....	11
4-1	OUTLINES OF CIRCUIT .....	11
4-2	VERTICAL AMPLIFIER CIRCUIT .....	13
4-3	HORIZONTAL/TIME BASE CIRCUIT .....	13
SECTION 5	MAINTENANCE & ADJUSTMENTS .....	14
5-1	GENERAL .....	14
5-1-(1)	Preventive Maintenance .....	14
5-1-(2)	Cleaning .....	14
5-1-(3)	Recalibration .....	14
5-2	ADJUSTMENT AND CALIBRATION .....	14
5-2-(1)	PRELIMINARY PROCEDURE .....	14
5-2-(2)	POWER SUPPLY UNIT ADJUSTMENTS .....	16
5-2-(3)	VERTICAL AMPLIFIER UNIT ADJUSTMENTS .....	18
5-2-(4)	Horizontal/Time Base Unit Adjustments .....	18
SECTION 6	PARTS LIST .....	19
SECTION 7	SERVICING .....	27
7-1	VERTICAL AMPLIFIER UNIT .....	28
7-1-(1)	Vertical Amplifier Circuit Diagram .....	29
7-2	HORIZONTAL/TIME BASE UNIT .....	30
7-2-(1)	Horizontal/Time Base Circuit Diagram .....	31
7-3	POWER SUPPLY CIRCUIT DIAGRAM .....	32
7-3-(1)	Power Supply Unit .....	32

## SECTION 1

## INTRODUCTION

This model is a dual trace 20MHz oscilloscope using high brightness CRT.

The vertical amplifiers have high sensitivity of 5mV/DIV and the frequency characteristic response with the smooth rolloff exceeding 20MHz. The highest triggering sweep speed is 0.2  $\mu$ sec/DIV.

### FEATURES

- 1) Component Tester
- 2) Wide bandwidth & high sensitivity
- 3) Very low power consumption
- 4) High sensitivity X-Y mode
- 5) Z axis (intensity modulation)
- 6) TV VIDEO SYNC Filter
- 7) High frequency rejection filter in the trigger circuit
- 8) Front panel electrical trace rotator
- 9) Regulated power supply circuit for accuracy

COMPONENT TESTER is the special circuit with which a single component or components in or out of actual circuit board can be easily tested requiring no power to drive the circuit.

The display shows FAULTS of components, size of a component value, and characteristics of components, and half-dead components under a dynamic test.

## SECTION 2

## SPECIFICATIONS

### VERTICAL DEFLECTION

Deflection Factor	5mV to 20V/DIV on 12 ranges in 1-2-5 step with fine control.
Bandwidth	DC: DC to 20MHz(-3dB) AC: 10Hz to 20MHz(-3dB)
Risetime	Less than 17.5nsec
Overshoot	Less than 3%
Input Impedance	1M $\Omega$ shunted by 20pF $\pm$ 3pF(Max input: 600Vp-p or 300V DC + AC peak)
Operating Modes	Ch-1, CH-2, DUAL and ADD, CHOP/ALT
Chop Frequency	200kHz approx.
Channel Separation	Better than 60dB at 1kHz
CH-2 Polarity	CH-2 can be inverted

### TIME BASE

Type	Automatic and triggered. In automatic mode, sweep is obtained without input signal.
Sweep Time	0.2 $\mu$ sec to 0.5sec/DIV on 20 ranges in 1-2-5 step with fine control and X-Y
Magnifier	$\times$ 5 at all ranges
Linearity	Less than 3%

### TRIGGERING

Sensitivity	INT: 1 DIV or more EXT: 1 Vp-p or more
Source	INT, CH-2, LINE or EXT
Triggering Level	Positive and Negative, continuously variable level control Pull for AUTO
Range	20Hz to 20MHz or more
Sync	AC, HF Rej, TV(each + or -) At TV Sync TV-H(Line) and TV-V(Frame) sync are switched automatically by SWEEP TIME/DIV switch. TV-V: 0.5sec/DIV to 0.1msec/DIV TV-H: 50 $\mu$ sec/DIV to 0.2 $\mu$ sec/DIV

## HORIZONTAL DEFLECTION

Deflection Factor	5mV to 20V/DIV on 12 ranges in 1-2-5 step with fine control.
Frequency Response	DC to 1MHz(-3dB)
Input Impedance	1M $\Omega$ shunted by 20pF $\pm$ 3pF
Max Input Voltage	300V DC + AC peak or 600Vp-p
X-Y Operation	X-Y mode is selected by SWEEP TIME/DIV switch CH-1: Y axis CH-2: X axis
Intensity Modulation	Z Axis: TTL Level (3Vp-p $\sim$ 50V) + bright, - dark.

## OTHER SPECIFICATIONS

CRT HV	APPROX-2KV
Calibration Voltage	0.5Vp-p $\pm$ 5%, 1kHz Square Wave
Power Requirements	AC: 100V/120V/220V/240V/, 50/60Hz, 19W
Weight	7kg approx.
Dimensions	135 (H) $\times$ 320 (W) $\times$ 445 (D)mm

## SECTION 3

## OPERATION

### 3-1 INITIAL OPERATION

Inspect the carton for serious damage which might have caused failure of the instrument during transportation. If damage is noted, notify the agent you bought from before turning on.

### INITIAL AC OPERATION

1. Prior to any kind of operation of the instrument, proceed as follows to get familiarized with the instrument.
  - a) Set the POWER switch to OFF.
  - b) Turn all the three POSITION controls to mid-position.
  - c) Turn INTENSITY control to mid-position.
  - d) Push the PULL 5X MAG control for normal.
  - e) Pull TRIGGERING LEVEL control for AUTO.
  - f) The rest of the controls remain at any position for normal operation.
  - g) Check the line voltage.
2. Connect the AC line cable into the AC receptacle on the rear panel of the instrument, and plug into an AC power outlet.
3. Turn POWER to ON. After approximately 20 seconds, trace lines appear on CRT screen. If no trace lines appear, rotate INTENSITY clockwise till trace lines are easily observed.
4. Adjust FOCUS and INTENSITY controls for clear trace lines.
5. Readjust Vertical and Horizontal POSITION controls for locations required.
6. Connect a probe (10:1) to INPUT of CH-1 and hook the tip of the probe to CAL 0.5Vp-p output.
7. Rotate CH-1 Vertical attenuator VOLTS/DIV switch to 10mV/DIV and turn the VARIABLE on the same axis clockwise to detent. Turn TRIGGERING SOURCE to CH-1. Then a square-wave of 5 divisions is displayed on the screen.
8. If the square-wave is distorted, adjust the trimmer of the probe till it becomes a good square-wave.
9. Remove the probe tip from CAL 0.5Vp-p output. Now, the oscilloscope is ready for use.

3-2 CONTROLS & INDICATIONS

1. VERTICAL INPUT

Vertical input terminal for CH-1.

2. AC-GND-DC

Vertical input coupling for CH-1. In AC position, the DC component of input signal is blocked by a capacitor. In GND position, the input terminal opens and the input of the internal amplifier is grounded. In DC position, the input terminal is directly connected to the amplifier and all components of input signal are displayed.

3. MODE

CH-1 : Waveforms of CH-1 are displayed.

CH-2 : Waveforms of CH-2 are displayed.

DUAL: In the range from 0.5sec/DIV up to 1 msec/DIV, both channels are chopped at about 200kHz.

In the range from 0.5msec/DIV up to 0.2  $\mu$ sec/DIV, both channels are switched alternately.

ADD: CH-1 and CH-2 signals are added. By pulling (23) PULL INVERT, SUB mode is obtained.

4. VOLTS/DIV VARIABLE for CH-A.

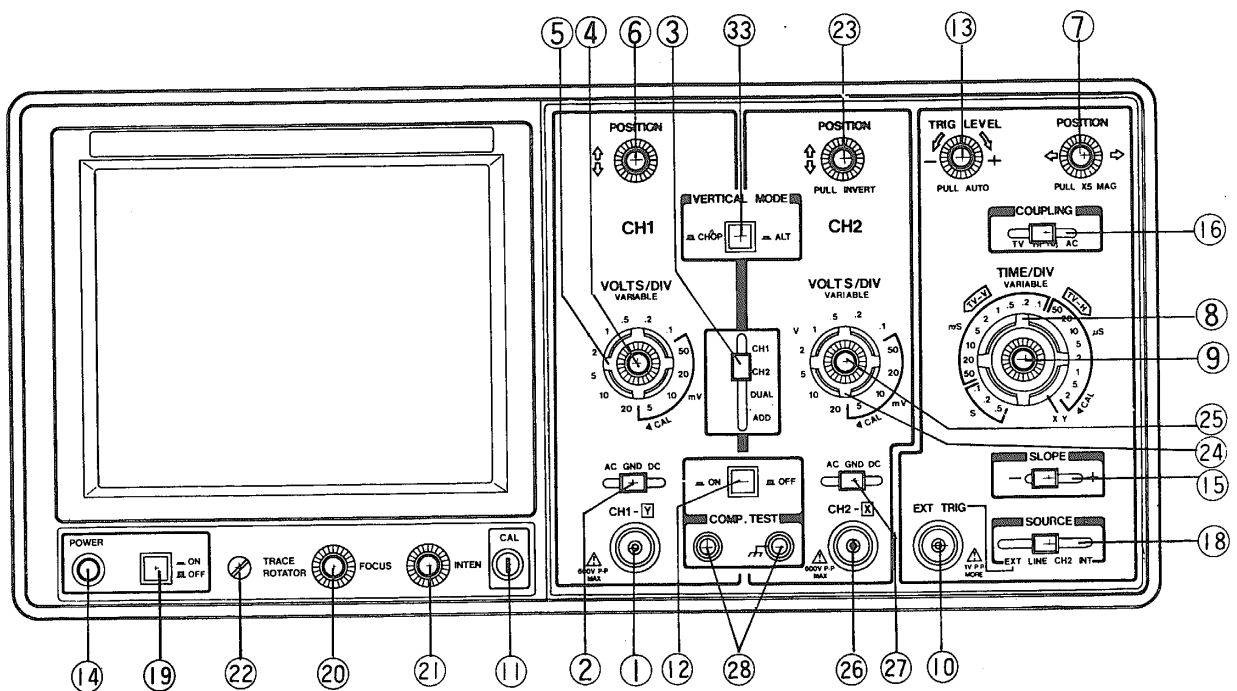

Fig. 1

5. VOLTS/DIV

Vertical attenuator for CH-1. The scale is graduated in voltage per "DIV" of CRT screen area.

Calibrated voltage is indicated when the VARIABLE is turned fully clockwise.

Selectable in 10 calibrated ranges from 5 mV/DIV to 20V/DIV.

6. VERTICAL POSITION

Vertical position adjuster for CH-1.

7. HORIZONTAL POSITION and PULL 5X MAG

Horizontal position adjuster. When pulled, SWEEP TIME is magnified by 5.

## 8. SWEEP TIME/DIV

Horizontal sweep time selector. It selects sweep times of  $0.2\mu\text{sec}/\text{DIV}$  to  $0.5\text{sec}/\text{DIV}$  in 20 calibrated steps. X-Y operation is possible by turning the knob fully clockwise to CH-2.

Change over between CHOP and ALTERNATE is also accomplished automatically by this selector in DUAL MODE

## 9. SWEEP TIME/DIV VARIABLE

## 10. EXT. TRIG

Input for external triggering signal.

## 11. CAL

Calibration voltage terminal. Calibration voltage is  $0.5\text{Vp-p}$  of about 1 kHz square wave.

## 12. COMP. TEST

Switch to change from oscilloscope to component tester.

For component testing ⑧ SWEEP TIME/DIV must be set to CH-2 for X-Y mode and also both ②-⑳ AC-GND-DC switches to GND positions.

## 13. TRIGGERING LEVEL

LEVEL control adjusts sync phase to determine the starting point of sweep on the slope of displayed waveform.

## PULL AUTO

By pulling LEVEL knob toward you, auto-sweep is effected; the sweep is set in free-running state even when no input signal is applied, with trace line displayed on CRT.

With trigger signal, triggered-sweep is effected where sync level is adjustable. When sync level is deviated, the sweep is set in free-running state.

## 14. POWER ON LAMP

## 15. SLOPE + , -

Sync slope polarity is selected.

## 16. COUPLING

Sync mode selector switch.

AC: For normal operation. In this mode sync signal is directly fed to the sync circuit.

HF REJ: Low Pass Filter cuts off RF composite of the sync signal.

TV: TV or Video composite signals are easily triggered.

SWEEP TIME/DIV selects TV-V ( $50\mu\text{sec}\sim 0.1\text{ msec}$ ) or TV-H ( $50\mu\text{sec}\sim 0.2\mu\text{sec}$ )

## 17. GND

Ground terminal.

## 18. SOURCE

Sync signal selector.

INT: CH-1 and CH-2 signals are added on for triggering.

CH-1: Sync signal for triggering comes only from CH-1. But, when in single sweep, the channel selected by MODE has priority.

CH-2: Signal from CH-2. The rest is the same as CH-1.

LINE: AC power line waveform is used as sync signal source.

EXT: The signal hooked into EXT TRIG becomes the sync signal source.

## 19. POWER SWITCH

Turns power on or off.

## 20. FOCUS

Focus control to obtain optimum waveform display.

## 21. INTENSITY

Adjust the brightness of waveform for easy viewing.



## 22. TRACE ROTATOR

The earth magnetics effect the trace line. Rotate this with a screw driver for proper trace line.

## 23. CH-2 POSITION, PULL INVERT

CH-2 vertical position control. When pulled, the CH-2 vertical polarity is inverted. This facilitates SUB MODE measurement at ADD MODE.

## 24. VOLTS/DIV

Vertical attenuator for CH-2.

## 25. VARIABLE

## 26. VERTICAL INPUT

Vertical input for CH-2.

## 27. AC-GND-DC

For CH-2, same as ②

## 28. COMPONENT TEST IN

Terminals to connect a component or lead wires to a component under test.

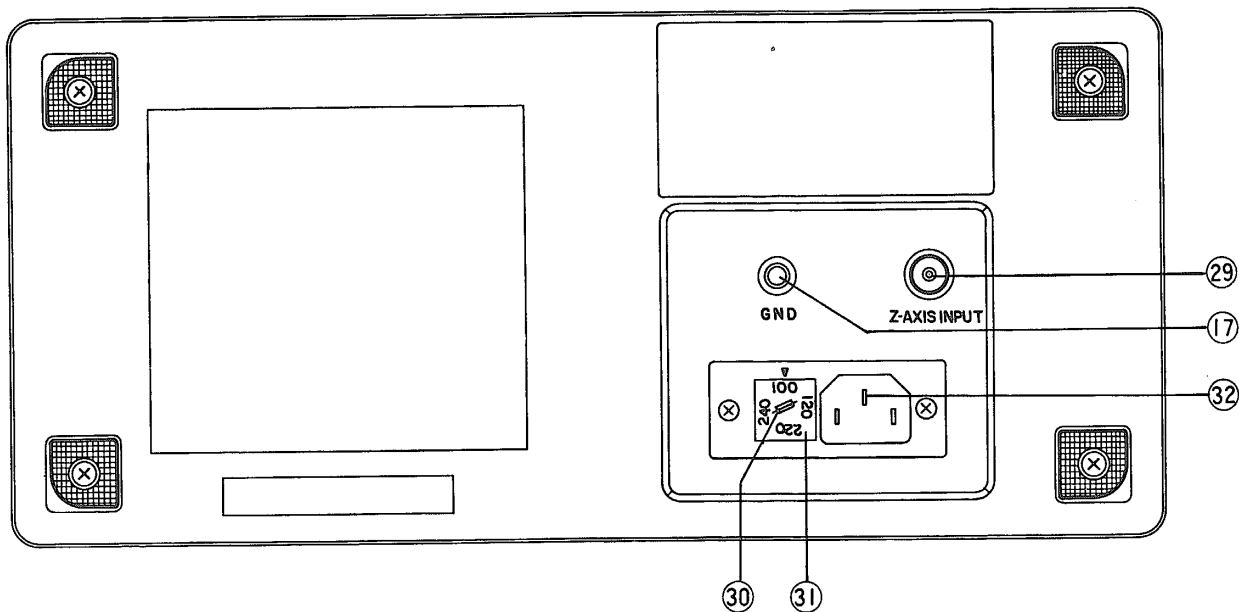

## 29. Z AXIS

External Intensity Modulation Input.

## 30. FUSE HOLDER

Proper ampere fuse must be in compartment

## 31. VOLTAGE SELECTOR

Proper line voltage must be selected where this oscilloscope is used.

## 32. RECEPTACLE for AC line cable.

## 33. CHOP/ALT

CHOP/ALT function is operated by TIME/DIV switch in the NORM position, and always being operated as ALT state in no-relation with TIME/DIV switch in the INV position.

## 3-3 TRIGGERING

Generally, triggered oscilloscopes have the following circuits to display stable waveform on the screen.

Vertical input signal or integral number related signal is used for a sync pulse signal, which is used as a triggering signal. This signal stabilizes the waveform display. However, this triggering must be exactly synchronized to the vertical input signal. And all the knobs should be correctly used.

This model has 4 knobs to control triggering. They are LEVEL, SLOPE, SYNC and SOURCE.

**(SOURCES)**

When the vertical input signal is supplied to the internal SYNC circuit, it is called INTERNAL TRIGGER.

When the same signal or integral number related signal is applied into the SYNC circuit through EXT TRIG input, it is referred as EXTERNAL TRIGGER. In this model INT, CH-1 and CH-2 of SOURCE switch are internal triggers.

The internal trigger signal is amplified in the vertical amplifier and triggering becomes easy.

LINE: The AC power line waveform is supplied to the SYNC circuit as a triggering source.

EXT: When SOURCE is turned to EXT, it becomes external trigger which has namely 3 benefits.

1. Triggering signal receives no effects from the vertical circuits.
  - EX. Triggering level need be readjusted when VOLTS/DIV knobs are turned because the sync source voltage changes. In such case, unless the external trig input voltage is changed, triggering is very stable and free from vertical controls.
2. Input signal can be easily delayed by the use of the delaying function of a pulse generator.
3. Composite signal or modulated signal can be easily triggered by the signal which composes the composite signal.

**(COUPLING)**

This switch has a selection of the sync circuit coupling. At AC position it becomes AC coupling and DC composite is isolated for stabilized synchronization. HF REJ has a low pass filter to eliminate RF noise interference to synchronization.

At TV position either vertical or horizontal sync signal isolation circuit works to ensure the TV signal triggering.

Selection of TV-V or TV-H is done by SWEEP TIME/DIV switch.

**(SLOPE)**

SLOPE switch +, - selects the triggering source signal slope of positive or negative.

At TV sync, triggering point is set to sync pulse rising time or falling time.

**(LEVEL)**

When this knob is pulled, it becomes AUTO for free running without the input signal for 0 level reference. When a signal is applied to the input, turn this knob for stable triggering.

**3-4 X-Y OPERATION**

For some special cases, this instrument is specially designed for easy X-Y application. Simply turn SWEEP TIME/DIV switch to CH-2. Then all CH-2 functions work as horizontal amplifier, whereas CH-1 remains as vertical amplifier.

**3-5 CALIBRATED VOLTAGE MEASUREMENTS**

Peak voltages, peak-to-peak voltages, DC voltages and voltages of a specific portion of a complex waveform can be measured using this instrument as a voltmeter. Voltages can be measured whenever waveforms are observed using either CH-1 or CH-2 inputs. Proceed as follows:

1. Set VARIABLE control fully clockwise to CAL position, then set VOLTS/DIV control to display the waveform in proper size to be observed. Vertical POSITION controls may be turned to obtain division reference.
2. For DC or complex signals, set the input switch to GND, and adjust the vertical POSITION control to a convenient reference level. Set the switch to DC and observe the amount of deflection. 1 positive voltage will deflect trace upwards: a negative voltage will deflect the trace downward. To calculate the voltage reading, multiply the vertical deflection (by division) by the setting of the VOLTS/DIV switch.

**NOTE** WHEN A PROBE (10:1) IS USED, THE WAVEFORM DISPLAY IS ONLY 1/10 OF THE ACTUAL VOLTAGE MEASURED.

**3-6 DUAL TRACE WAVEFORM OBSERVATION**

MODE switch to be turned to DUAL. Other procedures are in the same manner as mentioned above.

**3-7 TV SIGNAL SYNCHRONIZATION**

Set TRIGGERING SYNC to TV (+ or -), then specially designed circuitry provides easy triggering for complexed TV frame and line signal. TV frame and line waveform are easily obtained by simply tuning SWEEP TIME/DIV control.

3-8 ADD & SUB MEASUREMENTS

Simply turn MODE switch to ADD, added waveform of CH-1 and CH-2 is displayed.

With this MODE at ADD position, subtracted waveform is obtained by pulling INVERT knob which inverts the polarity of CH-2.

3-9 APPLICATIONS

This is a dual trace oscilloscope which has full capability of single trace mode. Thanks to the dual-trace functions, various effective measurements are feasible.

[SINGLE-TRACE APPLICATIONS]

Either Channel 1 or Channel 2 can be used for single-trace operation. Channel 1 is referred to hereunder for simplicity.

Set controls:

- AC-GND-DC . . . . . AC
- MODE . . . . . CH-1
- SYNC . . . . . NORM +
- SOURCE . . . . . INT
- PROBE . . . . . to CH-1 INPUT Jack

Connect the tip of the probe to the point in the circuit where the wave form is to be measured, and its ground clip to the chassis or the ground part.

**CAUTION !!!** THE PEAK-TO-PEAK VOLTAGE AT THE POINT OF MEASUREMENT SHOULD NOT EXCEED 600 VOLTS.

3-9-(1) AC VOLTAGE AND FREQUENCY MEASUREMENT

When measuring voltage and frequency, set VOLTS/DIV VARIABLES (4), (25) and SWEEP TIME/DIV VARIABLE (9) at their calibrated detent points (clockwise).

(EX) The signal displayed on the CRT is

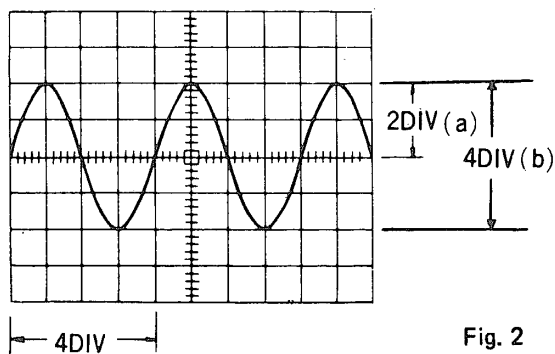

VOLT/DIV . . . . . at 2V  
 SWEEP TIME/DIV . . . . . at 5 msec.

Fig. 2

- (a) Peak voltage . . . . .  $2V/DIV \times 2DIV = 4$  volts
- (b) p-p voltage . . . . .  $2V/DIV \times 4DIV = 8$  volts
- (c) Effective voltage . . . . .  $Peak\ voltage \div \sqrt{2} = 2V \times 2DIV \times \frac{1}{\sqrt{2}} = 2.828$  volts
- (d) Frequency (Hz) . . . . .  $1/Time\ (second)$

Therefore, the Fig 2 waveform is:

$$Frequency = \frac{1}{5\ m\ sec \times 4\ (DIV)} = \frac{1}{20\ m\ sec} = 50Hz$$

\*\* Time = Number of DIVs for 1 cycle x value of SWEEP TIME/DIV

**NOTE !!!** The input of this oscilloscope is  $1M\Omega$  shunted by  $20pF$  capacitance. When the probe is used in 10:1 attenuation, the impedance becomes  $10M\Omega$  shunted by  $15pF$ . Then the voltage reading must be multiplied by 10.

**3-9-(2) DC VOLTAGE MEASUREMENT**

AC-GND-DC being at AC position, only AC or AC component was displayed on the CRT screen. For DC Measurement, set the switch to GND and pull the TRIGGERING LEVEL knob (13) for a trace line, which must be positioned at a certain place as 0 volt reference.

After that, turn the switch to DC. Then the trace line shifts up or down. The value of movement is the DC voltage.

$$\text{DC voltage} = \text{Shift (DIV)} \times \text{VOLTS/DIV}$$

When the trace line shifts up-ward, the polarity is (+), and down-ward is (-).

**3-9-(3) AM MODULATION MEASUREMENT**

There are various ways of measurements, but here in this manual the envelope method is introduced. This method is applicable when the carrier frequency is within the frequency bandwidth of the oscilloscope. See Fig. 3.

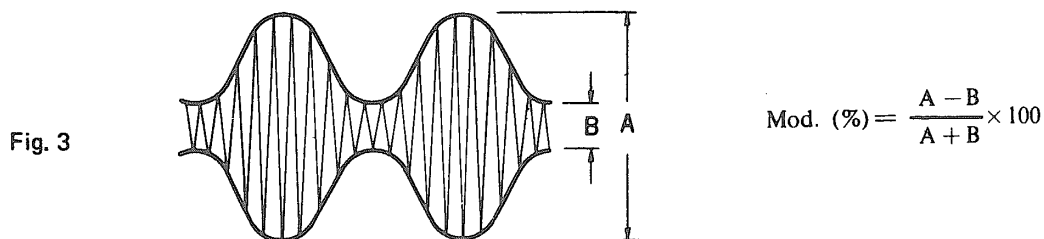
**3-9-(4) DUAL-TRACE APPLICATIONS**

MODE switch being turned to DUAL, both Channel 1 and Channel 2 works simultaneously.

Then, comparison of two relative signals are easily done such as level, waveforms, phase, etc.

**3-9-(5) LEVEL COMPARISON**

(EX) OUTPUT/INPUT of an amplifier

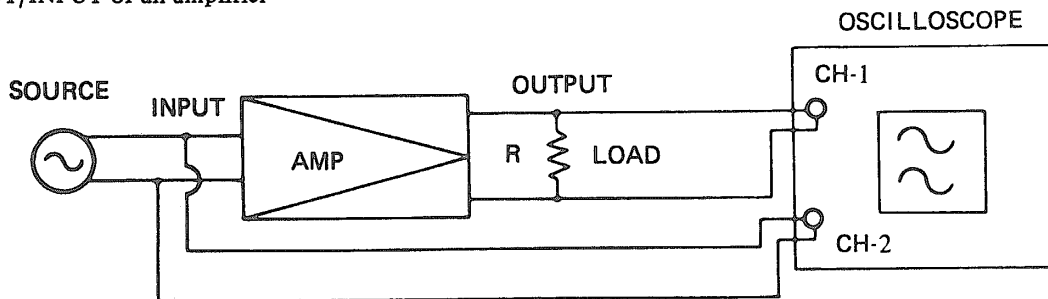

Fig. 4

With the connections of the Fig. 4 set the displays of CH-1 and CH-2 the same (POSITION controls be adjusted to place CH-2 waveform onto CH-1). Then the difference between displays of CH-1 VOLTS/DIV and CH-2's is the gain of the amplifier. If the two signals do not match each other even when variable controls are adjusted, the difference is the distortion caused in the amplifier. Then, simply turn the MODE switch to ADD and pull the CH-2 position knob for invert (SUB MODE), for viewing only distortion. When there is no distortion originated in the amplifier, a straight trace line is displayed in SUB MODE.

**3-9-(6) REPAIRING STEREO SYSTEMS**

Every stereo equipment has two symmetrical amplifier circuits.

So, simultaneous comparison of the same stages makes it so easy to locate defective point.

**3-9-(7) TV SERVICING**

Triggered oscilloscope is indispensable. This model has the very convenient TV SYNC circuits of TV-V (Frame) and TV-H (line) for accurate synchronization to view VIDEO SIGNAL, BLANKING PEDESTALS, VITS and Vertical/Horizontal SYNC PULSES.

**3-9-(8) COMPOSITE VIDEO ANALYSIS**

The most important waveform in TV servicing is the composite signal consisting of the video signal, the blanking pedestals, and sync pulses. Fig. 5 and Fig. 6 show composite signals synchronized with horizontal sync pulses and vertical blanking pulses.

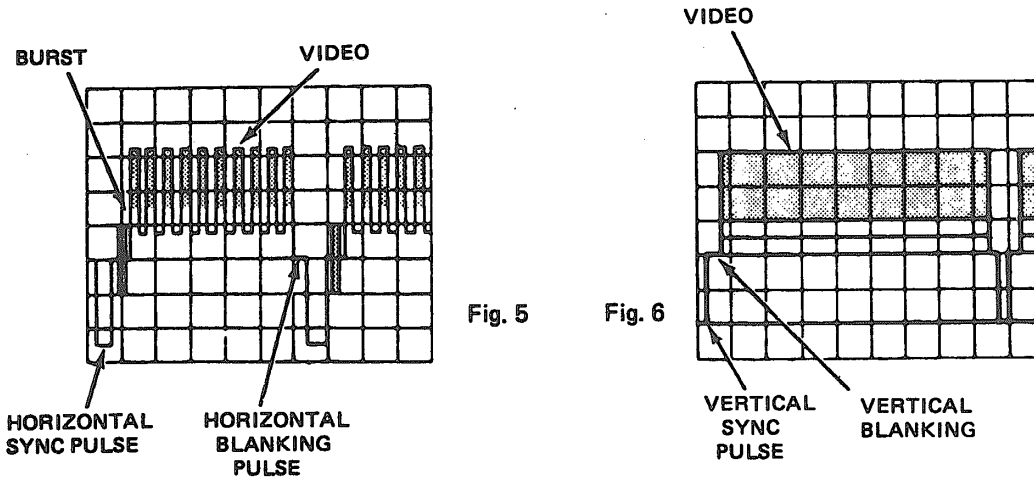

Fig. 5

Fig. 6

**3-9-(9) MEASUREMENT OF FREQUENCY BY X-Y**

Simply turn SWEEP/DIV switch to CH-2 for X-Y operation. Then CH-1 becomes Y axis and CH-2 X axis. Connect a standard frequency signal to CH-2 and unknown signal to CH-1. Lissajous figure is displayed on the screen as shown in Fig. 7.

Standard signal frequency: Unknown signal frequency



Fig. 7

**3-9-(10) PHASE MEASUREMENT**

In X-Y function, apply two signals to each CH-1 and CH-2. Calculate according to the formula.

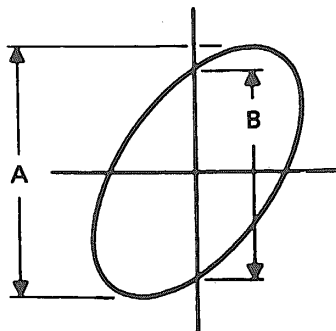

$$\text{SINE } \phi = \frac{B}{A}$$

$\phi$  = PHASE ANGLE

Fig. 8

**3-9-(11) PHOTOGRAPH**

CRT CAMERA (using Polaroid film) exact hood size camera for this oscilloscope is available.

3-9-(12) COMPONENT TEST

Turn SWEEP TIME/DIV knob to CH-2 (clockwise) for X-Y mode and set both AC-GND-DC switches to the GND position as well as setting the both VOLTS/DIV knob CH-1 to 2V/DIV, CH-2 to 5V/DIV, then push the COMP.

TEST SW. Components may be directly hooked to the COMP. TEST IN terminals or through lead wires.

Fig. 9 shows some reference displays.

**Note:** While in COMPONENT TEST operation, AC 9 VRMS is at the terminal for no load and about 2 mA will flow when they are shorted.

Fig. 9

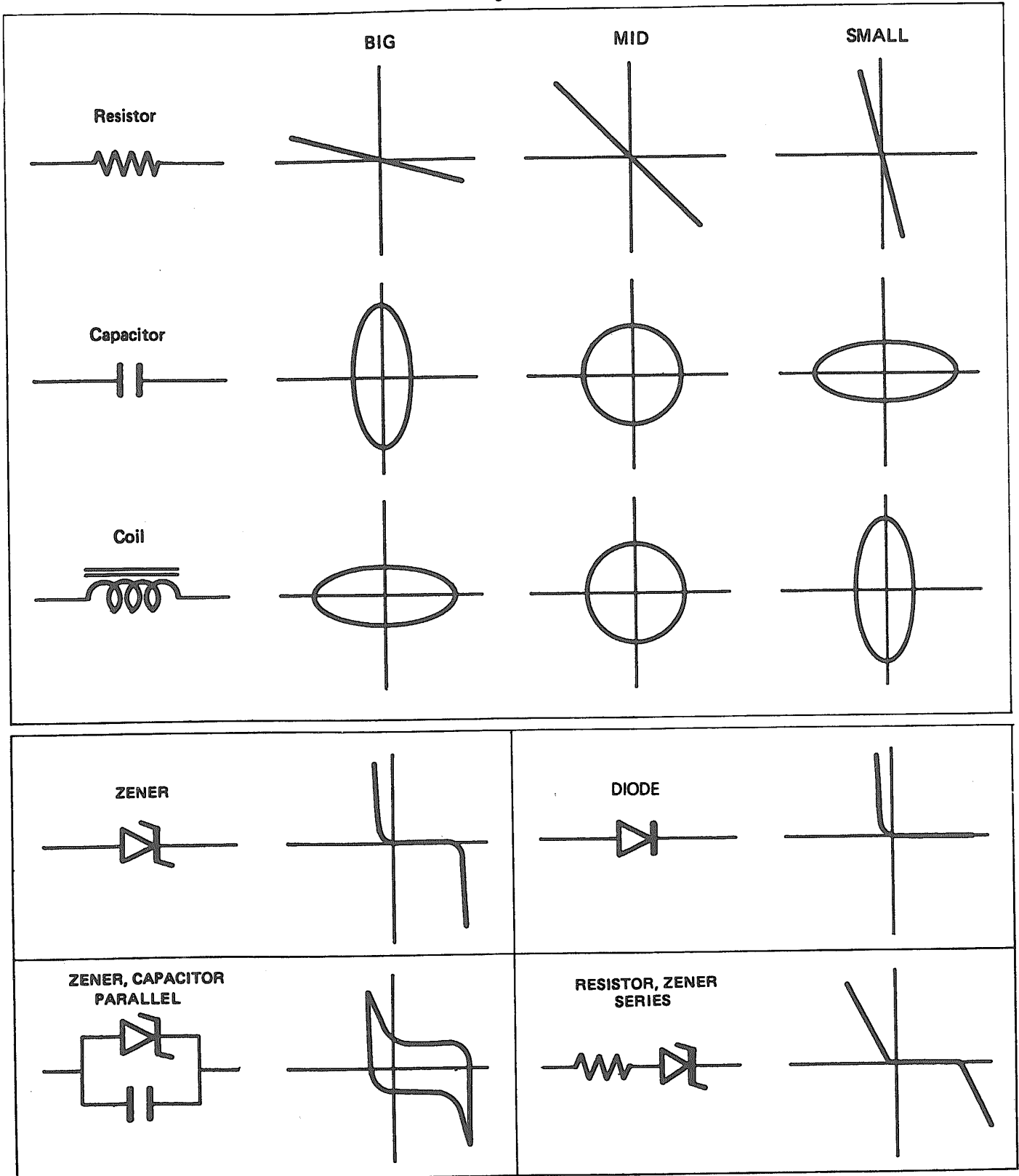

#### 4-1 OUTLINES OF CIRCUIT

Block diagram of this model is as Fig. 10.

This oscilloscope is equipped with 2 identical input attenuators and preamplifiers. The input signal is attenuated to the required level, amplified to the preamplifier, and led to the trigger pick off circuit, then to the switching circuit.

At the trigger pick off circuit, a part of the signal is picked up and fed to the trigger select logic for either CH-2, INT (CH-1 + CH-2) and led to the trigger amplifier of the TIME BASE Block.

The switching circuit consists of diode-gate and mode control logic to select CH-1, CH-2 and DUAL.

After the switching circuit the signal is amplified, and goes through a cascade type final stage amplifier for CRT vertical deflector.

The trigger signal or an external trigger signal is amplified and reformed as a clock pulse to drive the following saw tooth generator circuit, which consists of JKRS flip-flops and sweep controller, FET input Miller integrator, hold-off.

The tooth wave generated by the clock pulse, is led to a differential amplifier which, is equipped with a stabilized current supply, then fed to CRT horizontal deflector.

For X-Y operation, CH-2 input signal is led to the pick-off circuit, sweep X-Y selector, then horizontal final amplifier.

Q signal in the sweep control flip-flop and NAND of chopper rising edges are used for unblanking and chop-blanking. It is led to a cascade amplifier with a constant current load, a DC producing circuit and then added on to a high voltage, and then fed between the control grid and cathode of the CRT. The CRT is cut off during trace fly-back, and while waiting for trigger and chop change over time.

The power supplies are all regulated.

A feed back type DC-DC converter is used for generating the stabilized high voltage to CRT.

#### 4-2 VERTICAL AMPLIFIER CIRCUIT

The vertical input signal fed from the BNC input terminal is controlled by the AC-GND-DC switch and applied to the 1st attenuator, where 1/10 step (20dB) attenuation takes place. The out of input protection circuit Q1 (Q25) is fed to the DUAL FET through high input impedance. DUAL FET is well DC balanced against temperature variation. The output is then applied to the 2nd attenuator composed of U1 (U2). The 2nd attenuator makes the selection of 1/1, 1/2, 1/4 steps, modifying gain of U1 (U2). After being DC balanced, through VR1, 3, 4 (VR7, 9, 10), the output signal is fed to the diode switching circuit composed of D2-5, 16-19 as well as to the trigger amplifier made of Q7, 8, 31, 32.

The mode logic circuit which is controlled by the MODE switch, makes the selection of dual-trace, single-trace, CHOP and ALT possible. Dual-trace operation is obtained by the trigger select logic circuit driven by TRIG SOURCE switch, while the vertical MODE switch works prior to TRIG SOURCE switch and selects a proper trigger signal for single-trace operation.

In single trace operation triggering is automatically logic controlled according to the vertical MODE switch prior to Trigger SOURCE Selector.

In X-Y operation, controlled by the SWEEP TIME/DIV control, CH-2 signal is supplied to the trigger amplifier and fed to the horizontal amplifier as the X signal.

The vertical signal through diode switching circuit passes the limiter circuit of Q11, 12 and D6-9 to obtain the adequate level, and then is fed to the output amplifier composed of Q15-24. The output obtained is sufficiently amplified by the feedback-type amplifier with the constant current circuit (Q19, 20, 23, 24). This amplifier is equipped with the booster (Q21, 22) for high frequency contents to obtain flat response signals. The signal is then fed to the vertical deflection plates of CRT.

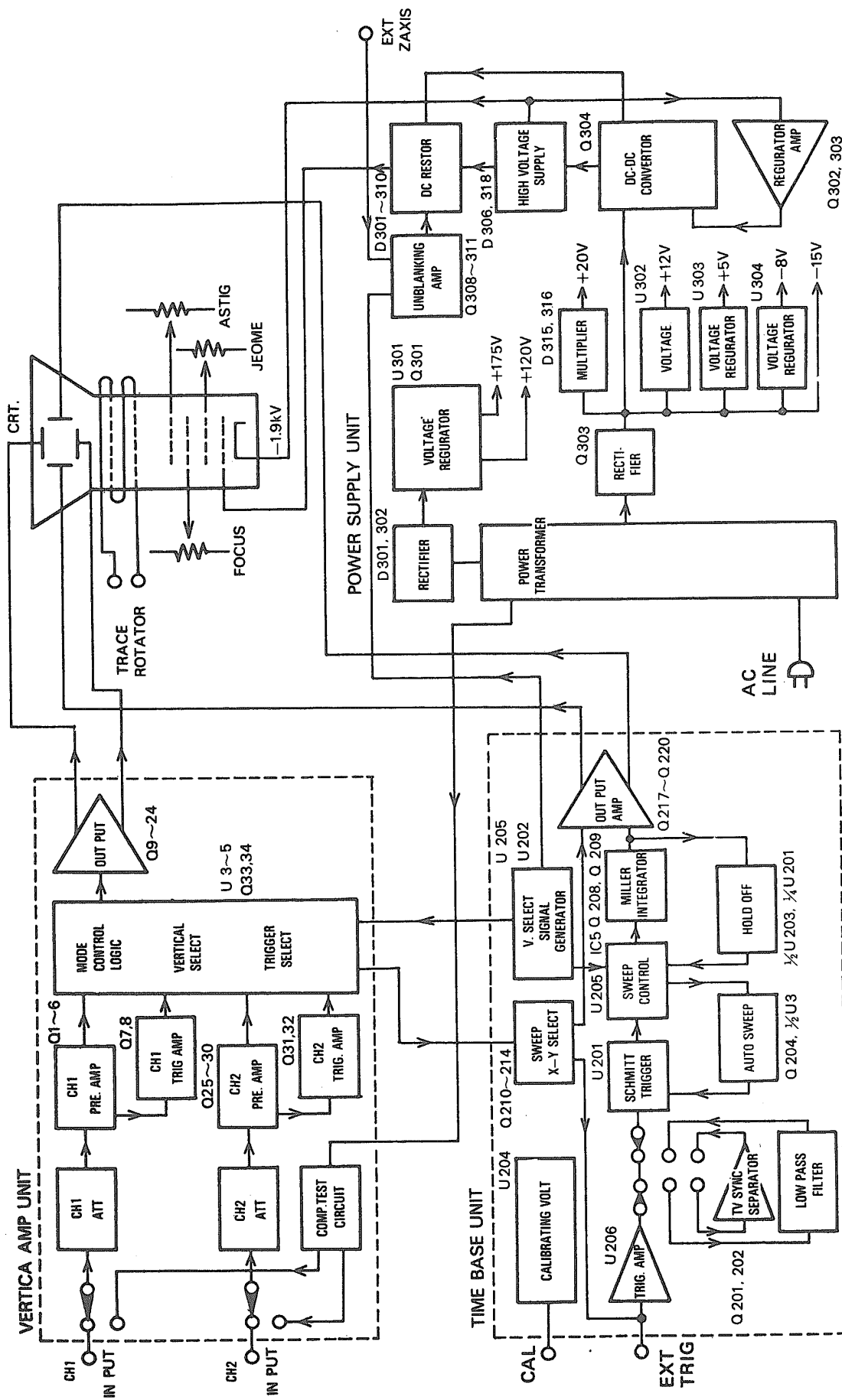

Fig. 10



### 4-3 HORIZONTAL/TIME BASE CIRCUIT

Time Base circuit consists of trigger section, the saw tooth section and amplifier section. The output from trigger select circuit is led to sweep X-Y select circuit (Q211~214). This select circuit works as the internal trigger amplifier and the sawtooth wave amplifier in normal operation, and as the amplifier for CH-2 signal in X-Y operation. The internal trigger signal is being amplified by U206 and then fed to schmitt circuit (1/2 U201). The external trigger signal is directly fed to U206. With TRIG SOURCE switch set to HF REJ, noises and high frequency components in the trigger source are eliminated. With TRIG SOURCE switch set to TV, IC output is connected to TV coupling separator (Q201, 202) to obtain horizontal coupling signal (TV-H) or vertical coupling signal (TV-V) and to supply it to schmidt circuit. Changeover between TV-H and TV-V is automatically accomplished by the SWEEP TIME/DIV switch. The signal in the schmitt trigger circuit is shaped into square waves and becomes clock pulses for sweep control gate (US205). The clock pulse is also supplied to auto sweep (Q204, 1/2 U203). With no trigger input, the output of the auto sweep circuit becomes low level, and therefore sweep control gate starts automatic sweeping. With triggering input, or supply of clock pulse, the output of auto sweep circuit becomes high level and the gate F.F. is inverted by the clock pulses and the Miller integrator becomes charged. Also, the output of auto-circuit actuates Q223 ON/OFF. When the gate F.F. is inverted, and sets Q207 to OFF, the Miller integrator determines the sweep time by the C/R time constant selected by the SWEEP TIME/DIV switch to obtain saw-tooth waves of excellent linearity. When the output from the Miller integrator fully rises, the Hold-off F.F. is inverted and the sweep stops for the time determined by the Hold-off time constant. When the Hold-off time passes, the next clock pulse is set in standby mode and thereby the sweep returns to the original status.

The output of this Miller integrator presses through sweep X-Y select circuit and is fed to the horizontal amplifier (Q217~220). In this amplifier, by use MAG X5 switch, sweep time is expanded by factor of 5. With SWEEP TIME/DIV switch set to X-Y position, sweep X-Y select circuit is switched to separate the Miller integrator from the horizontal amplifier and then the vertical CH-2 input is applied as horizontal input amplifier. In CHOP operation, blanking effects are given with the use of the horizontal Q output and CHOP signal generator. In ALT operation, the effects are given by Q output.

The output from multivibrator of U204 is shaped to obtain the calibrating voltage output. The variable resistor of VR205 is used to adjust the output level of 0.5p-p.

## SECTION 5

## MAINTENANCE & ADJUSTMENTS

### 5-1 GENERAL

This section contains information for preventive maintenance, adjustment and calibration.

#### 5-1-(1) PREVENTIVE MAINTENANCE

Preventive maintenance consists of periodic cleaning, and recalibration of the oscilloscope. It should be performed on a regular bases to keep the instrument in its best operational and appearance condition.

#### 5-1-(2) CLEANING

Accumulation of dirt, dust and grime should be removed whenever they become noticeable. The frequency of cleaning is largely dependent upon the environment in which the instrument is used. Dirt on the outside covers may be removed with a soft cloth moistened with a diluted household cleaning solution.

#### 5-1-(3) RECALIBRATION

Recalibration of the instrument at regular intervals will assure that measurements within the accuracy specification. It is recommended that the instrument be recalibrated after 1000 hours of operation, or twice a year. The calibration procedures are provided in the latter part of this section of the manual.

### 5-2 ADJUSTMENT AND CALIBRATION

Most of the problems resulting in a malfunction will be a defective component or a mechanical defect. Verify that the problem is not due to an incorrect switch position. The CRT display can be a valuable aid in pinpointing the area of many problems. The defect of any of the amplifiers, triggering circuit will be noticeable on the CRT.

#### Test Instruments Required

Instrument	Brief Specification
1. Digital Voltmeter	Range : 0 to 1000V DC Accuracy : Within 0.5%
2. 10 : 1 High Voltage Divider	$\pm 2\%$
3. Square wave generator	1KHz ~ 1MHz, Resetime < 5nS
4. Oscillator	1KHz ~ over 20MHz
5. Time Mark Generator	Pulse ranges from 0.1 $\mu$ s to 0.5mS $\pm 1\%$
6. Cable	Male BNC to male BNC, 50 $\Omega$

#### 5-2-1 PRELIMINARY PROCEDURE

1. check that the 100V/117V/220V/240V/ and Voltage selector is properly set.
2. turn the instrument on and allow at least 20 minutes warm-up before starting the adjustment procedure.  
For the best overall accuracy, make adjustments in ambient temperature of +20°C to +30°C.

#### 5-2-2 POWER SUPPLY UNIT ADJUSTMENTS

Some problems may result severe loading on the power supplies. The power supply unit for the this model comprises a DC to DC converter. The normal operating frequency of the converter is approximately 40KHz. Modifying pulse width with the change of loads, this converter assures the constant voltage supply. When the secondary voltage of the converter is incorrect, remove the P304 and P307 connectors of the Power Supply unit for checking.

##### 1. Voltage Adjustments

- a) Connect Digital Voltmeter common (or -) lead to the 5th pin on connector P304. (or ground)
- b) Connect Digital Voltmeter V.  $\Omega$  (or +) lead to the 1st Pin on connector ) P304.
- c) Adjust VR306 until + 200V supply gives reading of + 200V  $\pm 0.5V$ .

## SECTION 5

## MAINTENANCE & ADJUSTMENTS

- d) Transfer Digital Voltmeter V.  $\Omega$  (or +) lead to the 2nd pin on connector P307.
  - e) Adjust VR301 for Digital Voltmeter reading of  $-1.9 \text{ KV} \pm 5\text{V}$ .
  - f) Disconnect Digital Voltmeter.
2. Adjustments of intensity limit, Astigmatism, Trace Alignments.
- a) Set Time/Div. switch to CH 2 position.
  - b) Center beam using Position (  $\updownarrow$  ).
  - c) Rotate Intensity to 10 o'clock position.
  - d) Adjust VR305 (intensity limit adjustment) so beam is just extinguished.
  - e) Adjust INTENSITY to obtain normal spbt brightness and FOCUS to center position.
  - f) Adjust Astigmatism adjustment, VR303 and jeome adjustment, VR304 to get a sharp, round dot.
  - g) Set TIME/DIV. switch to  $0.5\mu\text{s}$  position.
  - h) when fly-back line appears on the CRT with trace line, adjust VR302 until the fly-back line is minimized.
  - i) repeat step a to f
  - j) Adjust trace rotator so that trace is parallel with horizontal graticule lines. Local magnetic field affects this setting.

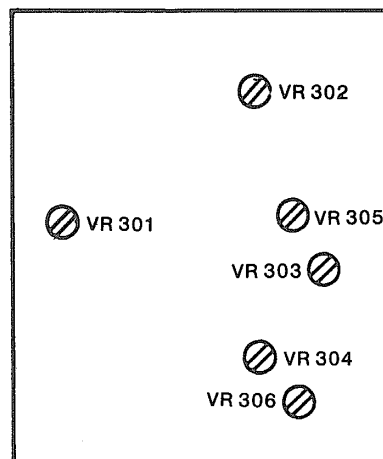

Fig. 12  
POWER SUPPLY UNIT  
290-1017-33

## 5-2-3 VERTICAL AMPLIFIER UNIT ADJUSTMENTS

## 1. Adjustments of preamplifier

a) Preliminary control setting : preset front panel controls as follows:

Intensity	Midrange
Focus	Midrange
Vertical Mode	CH A
Volts/Div. (both)	10mV
AC-GND-DC (both)	GND
Variable	Detent
Time/Div.	0.5mS
Source	INT
SYNC	NORM +
Level	Midrange and pull auto
Position (All)	Midrange

b) short TP terminal of V-PCB.

c) Adjust VR6 so that sweep lines could be at the center of CRT.

d) open TP terminal

e) Use CH 1 Position (  $\downarrow$  ) control to set trace on center horizontal graticule line.

f) Adjust VR1 (VR7 for CH 2) for no trace shift while switching CH 1 Volts/Div control between 2mV and 10mV.

g) Adjust VR3 (VR9 for CH 2) until no trace shift occurs when CH 1. Variable move between minimum and maximum.

h) Rotate CH 1 Position (  $\downarrow$  ) to 12 o'clock position and adjust VR4 (VR10 for CH 2) so that sweep lines could be at the center of CRT.

i) Repeat steps e) through h) for CH 2.

## 2. Adjustments of attenuator

a) Set CH 1 Volts/Div switch to 0.1V setting and Time/Div switch to 20 $\mu$ s setting.

b) Set vertical Mode switch to CH 1

c) Connect square-wave generator (600 $\Omega$  output) to CH 1 input connector.

d) Set square-wave generator control for 1 KHz output with sufficient amplitude to produce 6 divisions of vertical deflection.

e) Adjust TC1 (TC7 for CH 2) compensation adjustments to achieve squarest corners on the displayed waveform.

f) Set square wave generator for 1KHz signal 6 divisions of vertical deflection.

g) Adjust input capacitor adjustment TC2 (TC8 for CH 2) for best possible waveform.

h) Set Volts/Div switch to 1V settings. Adjust square wave generator output for 1 KHz and 6 divisions of vertical deflection.

i) Adjust TC3 (TC9 for CH 2) compensation adjustment to achieve squarest corners on displayed waveform.

j) Set square wave generator controls for 1KHz output with sufficient amplitude to produce 6 divisions of vertical deflection.

k) Adjust input capacitors TC4 (TC10 for CH 2) for best possible wave form.

l) Set Volts/Div switch to 10V settings. Adjust square wave generator output for 1 KHz and 6 divisions of vertical displays.

m) Adjust TC5 (TC11 for CH 2) compensation adjustment to achieve squarest corners on displayed waveform.

n) Set square wave generator control for 1KHz output with sufficient amplitude to produce 6 division of verticle deflection.

o) Adjust input capacitors TC6 (TC12 for CH 2) for best possible waveform.

p) Repeat steps a through O for CH 2.

q) Setting

## SECTION 5

## MAINTENANCE & ADJUSTMENTS

Volts/Div (both)	0.1V
CH 1 AC-GND-DC	DC
CH 2 AC-GND-DC	GND
Verticle Mode	CH 1
Time/Div	1 $\mu$ S
Source	INT
SYNC	NORM +
Level	Midrange and Pull Auto

- r) Adjust square wave generator output for 100KHz and 6 division of verticle display.
  - s) Adjust TC13 until squarest waveform.
  - t) Adjust TC14 (CH-1) and TC50 (CH 2) until squarest waveform for over shoot and under shoot
  - u) Adjust VR13 until no waveform distortion occurs when position ( $\updownarrow$ ) control between up and down.
3. Adjustment of Vertical gain

a) Setting

Volts/Div (both)	2mV
Vertical Mode	CH 1
AC-GND-DC (both)	DC
Time/Div	0.5mS
Source	INT
SYNC	NORM +
Level	Midrange and Pull Auto

- b) Connect Oscillator to CH 1 input connector.
- c) Set Oscillator for 1KHz at exactly 10mV p-p Amplitude.
- d) Adjust Verticle gain adjustment VR5 (VR11 for CH 2) for exactly 5 divisions of verticle deflection.  
This ensures 3% accuracy in the vertical amplifier.
- e) Set vertical Mode to CH 2.
- f) Repeat steps b) through d) for CH 2.
- g) Set Time/Div. switch to CH 2 position and CH 2 Volts/Div switch to 20mV setting. Center beam using position ( $\updownarrow$ ) controls.
- h) Connect Oscillator to CH 2 input connector and Set Oscillator for 1KHz at exactly 10mV P-P amplitude.
- i) Adjust VR 12 for exactly 5 divisions of horizontal deflection.
- j) Disconnect Oscillator.

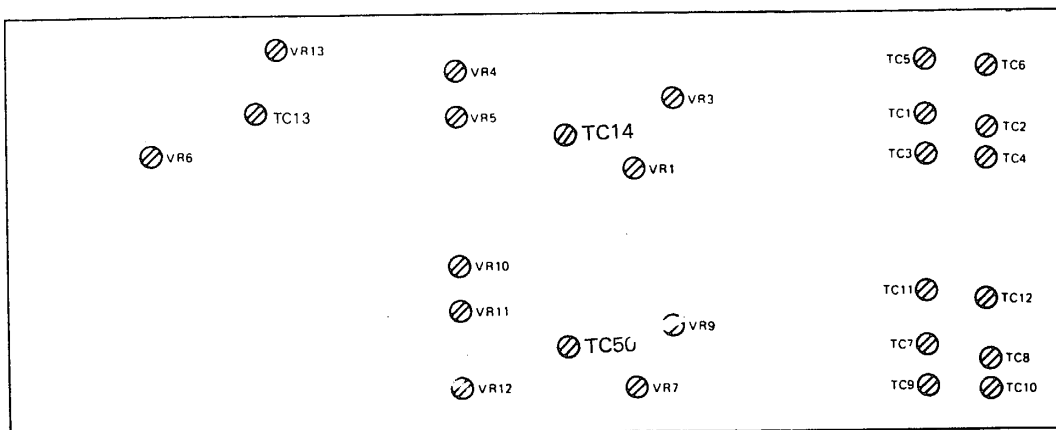

Fig. 13  
VERTICAL AMPLIFIER UNIT  
290-1016-34

5-2-4 Horizontal/Time Base Unit Adjustments.

1. Adjustment of Sweep Time/Div.

- a) setting.
 

Volts/Div (both)	0.1mV
Vertical Mode	CH 1
Time/Div	0.1mS
Source	INT
SYNC	NORM +
Level	Midrange and Pull Auto

- b) Connect Time marker generator to CH 1 input connector and set generator for 0.1mS marker interval.
- c) Adjust VR208 so that lie on vertical graticule lines.
- d) Set generator for 1μS marker interval and 620C sweep to 1μS.
- e) Adjust TC202 so that time marker again co-incide with vertical line of graticule.
- f) Set generator for 0.5μS marker interval and Time/Div switch to 0.5μS settings.
- g) Adjust TC201 so that markers lie on Vertical graticule and adjust VR214 for realignment of the range of 0.2μS/Div.
- h) Set Time/Div switch to 0.1mS setting and set generator for a 0.1mS marker interval.
- i) Set 5 X MAG switch to pull.
- j) Adjust VR212 for exactly 5 divisions of horizontal deflection and then push MAG switch.
- k) Adjust VR207 to obtain the same center position when the display is magnified.
- l) Adjust of sweep linearity: Adjust VR210 so that sine wave could not be concentrated at one side under time 0.1mS/Div.
- m) Adjustment of triggering: Adjust VR205 so that both (Sync + or -) start at the same point.

- 2. ADJUSTMENT OF X-AXIS (CH-2) POSITION. . . . . With SWEEP TIME/DIV. control set at CH-2, check if shift range is balanced when X-axis POSITION (CH-2 VERTICAL POSITION) is turned. If there is unbalance, Adjust VR209 and then Adjust VR211 to be at the center of X-axis.
- 3. ADJUSTMENT OF TRACE LINE LENGTH . . . . . Adjust VR213 to obtain the length of 11DIV on CRT screen.
- 4. ADJUST VR201 VR202 AND VR203 for CALIBRATION. . . . . To be 0.5V P-P when 1:1 probe is connected to the terminal of front panel calibration under VOLT/DIV 0.1V and TIME/DIV 0.1ms
- 5. ADJUST TC205 FOR 0.5 sec LENGTH. . . . . The length of trace line could be reached on the CRT surface when you input 0.5μS pulse under TIME/DIV 0.5μS range.
- 6. ADJUST TC204 FOR 0.5 sec/DIV MAG LINEARITY. . . . . Same as 3 adjustment after you draw PULL 5 X MAG SWITCH
- 7. Adjust VR215 for jittering.
- 8. Adjust TC203 for unblanking start position.

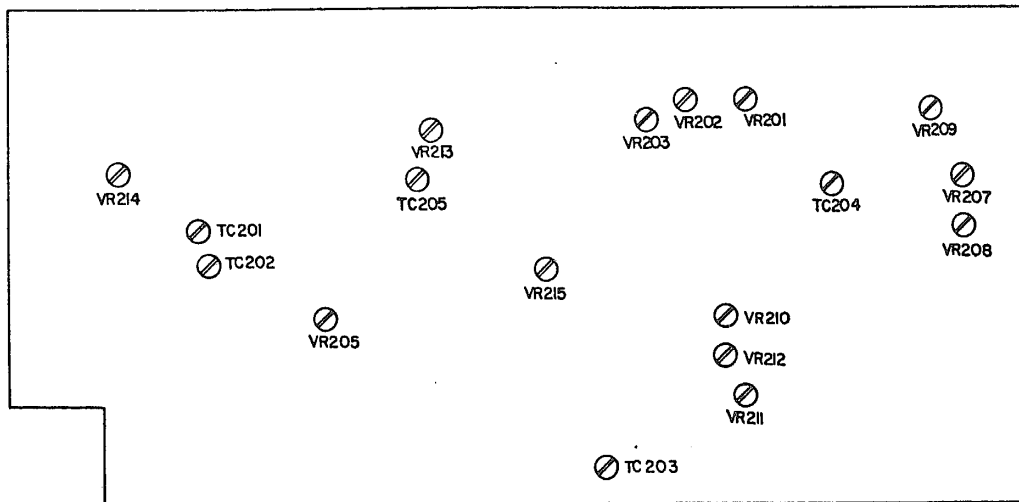

**FOIL SIDE VIEW**  
**CALIBRATION LOCATIONS FOR HORIZONTAL/TIME BASE UNIT**  
 290-1004-14

## SECTION 6

## PARTS LIST

CODE	REF-NO	DESCRIPTION	SPECIFICATION	UNIT	Q'TY
01-00010	U1, 2	IC	CA3086 (or HA1127G)	EA	2
01-00011	U3	IC	MC14001B	EA	1
01-00012	U4	IC	MC14011B	EA	1
01-00013	U5	IC	SN74LS03N	EA	1
01-00014	U201	IC	SN74LS00	EA	1
01-00015	U202	IC	SN7400	EA	1
01-00016	U203, 204	IC	MC14572UB	EA	2
01-00017	U205	IC	SN74LS76	EA	1
01-00018	U206	IC	UA733CN	EA	1
01-00019	U301	IC	UA741TC	EA	1
01-00020	U303	IC	UA7805	EA	1
01-00021	U302	IC	UA7812	EA	1
01-00022	U304	IC	UA7908	EA	1
01-00023	U305	IC	UA78L15	EA	1
02-00010	Q21, 22	Transistor PNP T092 Type	2SA781K	EA	2
02-00011	Q7, 8, 12~14, 31, 32, 207	Transistor PNP	2SA836D T0-92 Type	EA	19
02-00012	Q19, 20	Transistor PNP B100 Type	2SA1144Y (or 2SA1360Y)	EA	2
02-00013	Q301	Transistor PNP ; Y220b Type	2SA968 (or 2SB596)	EA	1
02-00014	Q11, 15, 16, 23, 24, 33,	Transistor NPN ; T092 Type	2SC458D	EA	23
02-00015	Q3~6, 9, 10, 27~30	Transistor NPN ; T092 Type	2SC535B	EA	10
02-00016	Q219, 220	Transistor NPN ; B100 Type	2SC2704Y (or 2SC3423)	EA	2
02-00017	Q308, 309, 312	Transistor NPN ; R182a Type	2SC1885 (or 2SC2632)	EA	3
02-00018	Q304	Transistor NPN ; Y220b Type	2SD401K	EA	1
02-00019	Q17, 18	Transistor NPN ; B100 Type	BF458	EA	2
02-00030	Q1, 25, 208	FET T092 Type	2SK30A(G)	EA	3
02-00031	Q2, 26	FET Dual	2SK228T	EA	2
03-00010	D10, 14, 211, 212, 311	Diode, Zener	HZ5C2	EA	5
03-00011	D314	Diode, Zener	HZ4B3	EA	1
03-00012	D317	Diode, Zener	HZ6C2	EA	1
03-00013	D219	Diode, Zener	HZ12C2	EA	1
03-00020	D301~303	Diode, Bridge	2W02	EA	3
03-00030	D204	Diode, GE ; D07 Type	1N60	EA	1
03-00040	D205, 210, 217	Diode, SI	1S1587 (or 1S1060)	EA	3
03-00041	D1~9, 11, 15~21, 23, 24,	Diode, SI	1S1588 (or 1S1040)	EA	36
03-00042	D307~310	Diode, SI	1SS83	EA	4
03-00043	D306, 318	Diode, SI: High Voltage	Y16GA	EA	2
03-00044	D315, 316	Diode, SI	V006C	EA	2
03-00050	LED1	LED Power Lamp	Green	EA	1
03-00060	TH1	Thermister	SDT 1000 (10K)	EA	1
04-00010	VR312	Resistor, Variable	2M ohm; Model 149	EA	1
04-00011	VR310	Resistor, Variable	50KB Ohm 15S; VM10A	EA	1
04-00012	VR311	Resistor, Variable	50KB Ohm 20S; VM10A	EA	1
04-00013	VR20	Resistor, Variable	1KB Ohm 15S; VM10A	EA	1
04-00014	VR2, 8	Resistor, Variable	5KB Ohm; VM11R	EA	2
04-00015	VR221	Resistor, Variable	20KB Ohm; VMBA5M3121,;15S	EA	1
04-00016	VR21	Resistor, Variable	1KB Ohm; VM13AVER22,;15S	EA	1
04-00017	VR204	Resistor, Variable	20KB Ohm, VM13AVER22 15S	EA	1
04-00020	VR1, 7, 13, 210	Resistor, Semi Fixed	1KB Ohm, RH1051C Type	EA	4
04-00021	VR302	Resistor, Semi Fixed	10KB Ohm, RH1051C Type	EA	1
04-00022	VR213, 214, 305	Resistor, Semi Fixed	100KB Ohm, RH1051C Type	EA	3
04-00023	VR3, 5, 9, 11, 12	Resistor, Semi Fixed	100B Ohm, RH1051C Type	EA	5
04-00024	VR4, 10, 306	Resistor, Semi Fixed	2.2KB Ohm, RH1051C Type	EA	3
04-00025	VR209	Resistor, Semi Fixed	22KB Ohm, RH1051C Type	EA	1
04-00026	VR211	Resistor, Semi Fixed	220B Ohm, RH1051C Type	EA	1
04-00027	VR215, 203	Resistor, Semi Fixed	4.7KB Ohm, RH1051C Type	EA	2
04-00029	VR212	Resistor, Semi Fixed	470B Ohm, RH1051C Type	EA	1
04-00030	VR303, 304	Resistor, Semi Fixed	1MB Ohm, RH1051C Type	EA	2
04-00031	VR201, 202, 205, 207,	Resistor, Semi Fixed	47KB Ohm, RH1051C Type	EA	6

## SECTION 6

## PARTS LIST

CODE	REF-NO	DESCRIPTION	SPECIFICATION	UNIT	Q'TY
01-00010	U1, 2	IC	CA3086 (or HA1127G)	EA	2
01-00011	U3	IC	MC14001B	EA	1
01-00012	U4	IC	MC14011B	EA	1
01-00013	U5	IC	SN74LS03N	EA	1
01-00014	U201	IC	SN74LS00	EA	1
01-00015	U202	IC	SN7400	EA	1
01-00016	U203, 204	IC	MC14572UB	EA	2
01-00017	U205	IC	SN74LS76	EA	1
01-00018	U206	IC	UA733CN	EA	1
01-00019	U301	IC	UA741TC	EA	1
01-00020	U303	IC	UA7805	EA	1
01-00021	U302	IC	UA7812	EA	1
01-00022	U304	IC	UA7908	EA	1
01-00023	U305	IC	UA78L15	EA	1
02-00010	Q21, 22	Transistor PNP T092 Type	2SA781K	EA	2
02-00011	Q7, 8, 12~14, 31, 32, 207	Transistor PNP	2SA836D T0-92 Type	EA	19
02-00012	Q19, 20	Transistor PNP B100 Type	2SA1144Y (or 2SA1360Y)	EA	2
02-00013	Q301	Transistor PNP ; Y220b Type	2SA968 (or 2SB596)	EA	1
02-00014	Q11, 15, 16, 23, 24, 33,	Transistor NPN ; T092 Type	2SC458D	EA	23
02-00015	Q3~6, 9, 10, 27~30	Transistor NPN ; T092 Type	2SC535B	EA	10
02-00016	Q219, 220	Transistor NPN ; B100 Type	2SC2704Y (or 2SC3423)	EA	2
02-00017	Q308, 309, 312	Transistor NPN ; R182a Type	2SC1885 (or 2SC2632)	EA	3
02-00018	Q304	Transistor NPN ; Y220b Type	2SD401K	EA	1
02-00019	Q17, 18	Transistor NPN ; B100 Type	BF458	EA	2
02-00030	Q1, 25, 208	FET T092 Type	2SK30A(G)	EA	3
02-00031	Q2, 26	FET Dual	2SK228T	EA	2
03-00010	D10, 14, 211, 212, 311	Diode, Zener	HZ5C2	EA	5
03-00011	D314	Diode, Zener	HZ4B3	EA	1
03-00012	D317	Diode, Zener	HZ6C2	EA	1
03-00013	D219	Diode, Zener	HZ12C2	EA	1
03-00020	D301~303	Diode, Bridge	2W02	EA	3
03-00030	D204	Diode, GE ; D07 Type	1N60	EA	1
03-00040	D205, 210, 217	Diode, SI	1S1587 (or 1S1060)	EA	3
03-00041	D1~9, 11, 15~21, 23, 24,	Diode, SI	1S1588 (or 1S1040)	EA	36
03-00042	D307~310	Diode, SI	1SS83	EA	4
03-00043	D306, 318	Diode, SI:High Voltage	Y16GA	EA	2
03-00044	D315, 316	Diode, SI	V006C	EA	2
03-00050	LED1	LED Power Lamp	Green	EA	1
03-00060	TH1	Thermister	SDT 1000 (10K)	EA	1
04-00010	VR312	Resistor, Variable	2M ohm; Model 149	EA	1
04-00011	VR310	Resistor, Variable	50KB Ohm 15S; VM10A	EA	1
04-00012	VR311	Resistor, Variable	50KB Ohm 20S; VM10A	EA	1
04-00013	VR20	Resistor, Variable	1KB Ohm 15S; VM10A	EA	1
04-00014	VR2, 8	Resistor, Variable	5KB Ohm; VM11R	EA	2
04-00015	VR221	Resistor, Variable	20KB Ohm; VMBA5M3121,;15S	EA	1
04-00016	VR21	Resistor, Variable	1KB Ohm; VM13AVER22,;15S	EA	1
04-00017	VR204	Resistor, Variable	20KB Ohm, VM13AVER22 15S	EA	1
04-00020	VR1, 7, 13, 210	Resistor, Semi Fixed	1KB Ohm, RH1051C Type	EA	4
04-00021	VR302	Resistor, Semi Fixed	10KB Ohm, RH1051C Type	EA	1
04-00022	VR213, 214, 305	Resistor, Semi Fixed	100KB Ohm, RH1051C Type	EA	3
04-00023	VR3, 5, 9, 11, 12	Resistor, Semi Fixed	100B Ohm, RH1051C Type	EA	5
04-00024	VR4, 10, 306	Resistor, Semi Fixed	2.2KB Ohm, RH1051C Type	EA	3
04-00025	VR209	Resistor, Semi Fixed	22KB Ohm, RH1051C Type	EA	1
04-00026	VR211	Resistor, Semi Fixed	220B Ohm, RH1051C Type	EA	1
04-00027	VR215, 203	Resistor, Semi Fixed	4.7KB Ohm, RH1051C Type	EA	2
04-00029	VR212	Resistor, Semi Fixed	470B Ohm, RH1051C Type	EA	1
04-00030	VR303, 304	Resistor, Semi Fixed	1MB Ohm, RH1051C Type	EA	2
04-00031	VR201, 202, 205, 207,	Resistor, Semi Fixed	47KB Ohm, RH1051C Type	EA	6

## SECTION 6

## PARTS LIST

CODE	REF-NO	DESCRIPTION	SPECIFICATION	UNIT	Q'TY
04-00032	VR6	Resistor, Semi Fixed	470KB Ohm, RH1051C Type	EA	1
05-00010	R46, 153	Resistor, Metal Film	82 Ohm, 1/4W, F	EA	2
05-00011	R26, 131	Resistor, Metal Film	220 Ohm, 1/4W, F	EA	2
05-00012	R35, 138	Resistor, Metal Film	330 Ohm, 1/4W, F	EA	2
05-00013	R29, 31, 133, 135	Resistor, Metal Film	470 Ohm, 1/4W, F	EA	4
05-00014	R39, 40, 142, 143	Resistor, Metal Film	680 Ohm, 1/4W, F	EA	4
05-00015	R24, 129	Resistor, Metal Film	820 Ohm, 1/4W, F	EA	2
05-00016	R7, 23, 57, 60, 111, 127	Resistor, Metal Film	1K Ohm, 1/4W, F	EA	6
05-00017	R32, 136	Resistor, Metal Film	1.5K Ohm, 1/4W, F	EA	2
05-00018	R44, 45, 149, 150	Resistor, Metal Film	2.2K Ohm, 1/4W, F	EA	4
05-00019	R85, 93	Resistor, Metal Film	2.4K Ohm, 1/4W, F	EA	2
05-00020	R63	Resistor, Metal Film	3.3K Ohm, 1/4W, F	EA	1
05-00021	R346	Resistor, Metal Film	3.9K Ohm, 1/4W, F	EA	1
05-00022	R64, 66, 71	Resistor, Metal Film	4.7K Ohm, 1/4W, F	EA	3
05-00023	R12, 12, 116, 117	Resistor, Metal Film	6.8K Ohm, 1/4W, F	EA	4
05-00024	R21, 22, 125, 126	Resistor, Metal Film	8.2K Ohm, 1/4W, F	EA	4
05-00025	R5, 109	Resistor, Metal Film	10.1K Ohm, 1/4W, F	EA	2
05-00026	R36, 37, 139, 140	Resistor, Metal Film	12K Ohm, 1/4W, F	EA	4
05-00027	R80	Resistor, Metal Film	39K Ohm, 1/4W, F	EA	1
05-00028	R78, 82, 242, 244, 239	Resistor, Metal Film	100K Ohm, 1/4W, F	EA	5
05-00029	R3, 107	Resistor, Metal Film	111K Ohm, 1/4W, F	EA	2
05-00030	R345	Resistor, Metal Film	120K Ohm, 1/4W, F	EA	1
05-00031	R245	Resistor, Metal Film	300K Ohm, 1/4W, F	EA	1
05-00032	R2, 106	Resistor, Metal Film	900K Ohm, 1/4W, F	EA	2
05-00033	R4, 108	Resistor, Metal Film	990K Ohm, 1/4W, F	EA	2
05-00034	R6, 110	Resistor, Metal Film	999K Ohm, 1/4W, F	EA	2
05-00035	R8, 112, 247	Resistor, Metal Film	1M Ohm, 1/2W, F	EA	3
05-00036	R246	Resistor, Metal Film	500K Ohm, 1/2W, F	EA	1
05-00037	R248	Resistor, Metal Film	3M Ohm, 1/2W, F	EA	1
05-00038	R350	Resistor, Metal Graze	10M Ohm, 2W, F	EA	1
05-00039	R349	Resistor, Metal Oxide	10 Ohm, 1W, J	EA	1
05-00040	R381	Resistor, Metal Oxide	27 Ohm, 1W, J	EA	1
05-00041	R294, 296	Resistor, Metal Oxide	6.8K Ohm, 3W G	EA	2
05-00042	R317	Resistor, Carbon Film	750 Ohm, 1/2W, J	EA	1
05-00043	R298	Resistor, Carbon Film	100K Ohm, 1/2W J	EA	1
05-00044	R341, 342, 348	Resistor, Carbon Film	4.7 Ohm, 1/4W J	EA	3
05-00045	R25, 128, 172, 309	Resistor, Carbon Film	10 Ohm, 1/4W J	EA	4
05-00046	R310	Resistor, Carbon Film	11 Ohm, 1/4W J	EA	1
05-00047	R27, 130	Resistor, Carbon Film	15 Ohm, 1/4W J	EA	2
05-00048	R1, 47, 50, 65, 70, 79,	Resistor, Carbon Film	22 Ohm, 1/4W J	EA	36
05-00049	R10, 11, 17~20, 30, 33,	Resistor, Carbon Film	47 Ohm, 1/4W J	EA	36
05-00050	R382	Resistor, Carbon Film	33 Ohm, 1/4W J	EA	1
05-00051	R95, 103, 208, 217, 223,	Resistor, Carbon Film	100 Ohm, 1/4W J	EA	13
05-00052	R326	Resistor, Carbon Film	110 Ohm, 1/4W J	EA	1
05-00053	R154, 289	Resistor, Carbon Film	120 Ohm, 1/4W J	EA	2
05-00054	R51, 213, 214	Resistor, Carbon Film	150 Ohm, 1/4W J	EA	3
05-00055	R371	Resistor, Carbon Film	180 Ohm, 1/4W J	EA	1
05-00056	R104	Resistor, Carbon Film	220 Ohm, 1/4W J	EA	1
05-00057	R28, 61, 132	Resistor, Carbon Film	270 Ohm, 1/4W J	EA	3
05-00058	R193, 194	Resistor, Carbon Film	330 Ohm, 1/4W J	EA	2
05-00059	R357	Resistor, Carbon Film	390 Ohm, 1/4W J	EA	1
05-00060	R256, 286, 287, 288	Resistor, Carbon Film	470 Ohm, 1/4W J	EA	4
05-00061	R212	Resistor, Carbon Film	560 Ohm, 1/4W J	EA	1
05-00062	R97, 102	Resistor, Carbon Film	680 Ohm, 1/4W J	EA	2
05-00063	R276	Resistor, Carbon Film	820 Ohm, 1/4W J	EA	1
05-00064	R14, 62, 89, 187, 204,	Resistor, Carbon Film	1K Ohm, 1/4W J	EA	18
05-00065	R87, 91, 258, 261, 385	Resistor, Carbon Film	1.5K Ohm, 1/4W J	EA	5
05-00066	R265, 273, 280	Resistor, Carbon Film	1.8K Ohm, 1/4W J	EA	3



## SECTION 6

## PARTS LIST

CODE	REF-NO	DESCRIPTION	SPECIFICATION	UNIT	Q'TY
04-00032	VR6	Resistor, Semi Fixed	470KB Ohm, RH1051C Type	EA	1
05-00010	R46, 153	Resistor, Metal Film	82 Ohm, 1/4W, F	EA	2
05-00011	R26, 131	Resistor, Metal Film	220 Ohm, 1/4W, F	EA	2
05-00012	R35, 138	Resistor, Metal Film	330 Ohm, 1/4W, F	EA	2
05-00013	R29, 31, 133, 135	Resistor, Metal Film	470 Ohm, 1/4W, F	EA	4
05-00014	R39, 40, 142, 143	Resistor, Metal Film	680 Ohm, 1/4W, F	EA	4
05-00015	R24, 129	Resistor, Metal Film	820 Ohm, 1/4W, F	EA	2
05-00016	R7, 23, 57, 60, 111, 127	Resistor, Metal Film	1K Ohm, 1/4W, F	EA	6
05-00017	R32, 136	Resistor, Metal Film	1.5K Ohm, 1/4W, F	EA	2
05-00018	R44, 45, 149, 150	Resistor, Metal Film	2.2K Ohm, 1/4W, F	EA	4
05-00019	R85, 93	Resistor, Metal Film	2.4K Ohm, 1/4W, F	EA	2
05-00020	R63	Resistor, Metal Film	3.3K Ohm, 1/4W, F	EA	1
05-00021	R346	Resistor, Metal Film	3.9K Ohm, 1/4W, F	EA	1
05-00022	R64, 66, 71	Resistor, Metal Film	4.7K Ohm, 1/4W, F	EA	3
05-00023	R12, 12, 116, 117	Resistor, Metal Film	6.8K Ohm, 1/4W, F	EA	4
05-00024	R21, 22, 125, 126	Resistor, Metal Film	8.2K Ohm, 1/4W, F	EA	4
05-00025	R5, 109	Resistor, Metal Film	10.1K Ohm, 1/4W, F	EA	2
05-00026	R36, 37, 139, 140	Resistor, Metal Film	12K Ohm, 1/4W, F	EA	4
05-00027	R80	Resistor, Metal Film	39K Ohm, 1/4W, F	EA	1
05-00028	R78, 82, 242, 244, 239	Resistor, Metal Film	100K Ohm, 1/4W, F	EA	5
05-00029	R3, 107	Resistor, Metal Film	111K Ohm, 1/4W, F	EA	2
05-00030	R345	Resistor, Metal Film	120K Ohm, 1/4W, F	EA	1
05-00031	R245	Resistor, Metal Film	300K Ohm, 1/4W, F	EA	1
05-00032	R2, 106	Resistor, Metal Film	900K Ohm, 1/4W, F	EA	2
05-00033	R4, 108	Resistor, Metal Film	990K Ohm, 1/4W, F	EA	2
05-00034	R6, 110	Resistor, Metal Film	999K Ohm, 1/4W, F	EA	2
05-00035	R8, 112, 247	Resistor, Metal Film	1M Ohm, 1/2W, F	EA	3
05-00036	R246	Resistor, Metal Film	500K Ohm, 1/2W, F	EA	1
05-00037	R248	Resistor, Metal Film	3M Ohm, 1/2W, F	EA	1
05-00038	R350	Resistor, Metal Graze	10M Ohm, 2W, F	EA	1
05-00039	R349	Resistor, Metal Oxide	10 Ohm, 1W, J	EA	1
05-00040	R381	Resistor, Metal Oxide	27 Ohm, 1W, J	EA	1
05-00041	R294, 296	Resistor, Metal Oxide	6.8K Ohm, 3W G	EA	2
05-00042	R317	Resistor, Carbon Film	750 Ohm, 1/2W, J	EA	1
05-00043	R298	Resistor, Carbon Film	100K Ohm, 1/2W J	EA	1
05-00044	R341, 342, 348	Resistor, Carbon Film	4.7 Ohm, 1/4W J	EA	3
05-00045	R25, 128, 172, 309	Resistor, Carbon Film	10 Ohm, 1/4W J	EA	4
05-00046	R310	Resistor, Carbon Film	11 Ohm, 1/4W J	EA	1
05-00047	R27, 130	Resistor, Carbon Film	15 Ohm, 1/4W J	EA	2
05-00048	R1, 47, 50, 65, 70, 79,	Resistor, Carbon Film	22 Ohm, 1/4W J	EA	36
05-00049	R10, 11, 17~20, 30, 33,	Resistor, Carbon Film	47 Ohm, 1/4W J	EA	36
05-00050	R382	Resistor, Carbon Film	33 Ohm, 1/4W J	EA	1
05-00051	R95, 103, 208, 217, 223,	Resistor, Carbon Film	100 Ohm, 1/4W J	EA	13
05-00052	R326	Resistor, Carbon Film	110 Ohm, 1/4W J	EA	1
05-00053	R154, 289	Resistor, Carbon Film	120 Ohm, 1/4W J	EA	2
05-00054	R51, 213, 214	Resistor, Carbon Film	150 Ohm, 1/4W J	EA	3
05-00055	R371	Resistor, Carbon Film	180 Ohm, 1/4W J	EA	1
05-00056	R104	Resistor, Carbon Film	220 Ohm, 1/4W J	EA	1
05-00057	R28, 61, 132	Resistor, Carbon Film	270 Ohm, 1/4W J	EA	3
05-00058	R193, 194	Resistor, Carbon Film	330 Ohm, 1/4W J	EA	2
05-00059	R357	Resistor, Carbon Film	390 Ohm, 1/4W J	EA	1
05-00060	R256, 286, 287, 288	Resistor, Carbon Film	470 Ohm, 1/4W J	EA	4
05-00061	R212	Resistor, Carbon Film	560 Ohm, 1/4W J	EA	1
05-00062	R97, 102	Resistor, Carbon Film	680 Ohm, 1/4W J	EA	2
05-00063	R276	Resistor, Carbon Film	820 Ohm, 1/4W J	EA	1
05-00064	R14, 62, 89, 187, 204,	Resistor, Carbon Film	1K Ohm, 1/4W J	EA	18
05-00065	R87, 91, 258, 261, 385	Resistor, Carbon Film	1.5K Ohm, 1/4W J	EA	5
05-00066	R265, 273, 280	Resistor, Carbon Film	1.8K Ohm, 1/4W J	EA	3

## SECTION 6

## PARTS LIST

CODE	REF-NO	DESCRIPTION	SPECIFICATION	UNIT	Q'TY
05-00067	R67, 69, 211, 236, 278,	Resistor, Carbon Film	2.2K Ohm, 1/4W J	EA	6
05-00068	R52, 53, 155, 156, 184	Resistor, Carbon Film	3.3K Ohm, 1/4W J	EA	9
05-00069	R38, 42, 144, 145, 264,	Resistor, Carbon Film	3.9K Ohm, 1/4W J	EA	8
05-00070	R99, 100, 189, 224, 226,	Resistor, Carbon Film	4.7K Ohm, 1/4W J	EA	11
05-00071	R240	Resistor, Carbon Film	5.6K Ohm, 1/4W J	EA	1
05-00072	R203, 238, 304	Resistor, Carbon Film	6.8K Ohm, 1/4W J	EA	3
05-00073	R268, 277, 283	Resistor, Carbon Film	8.2K Ohm, 1/4W J	EA	3
05-00073	R268, 277, 283	Resistor, Carbon Film	8.2K Ohm, 1/4W J	EA	3
05-00074	R15, 120, 176, 190, 218	Resistor, Carbon Film	10K Ohm, 1/4W J	EA	13
05-00075	R16, 121	Resistor, Carbon Film	11K Ohm, 1/4W J	EA	2
05-00076	R228	Resistor, Carbon Film	12K Ohm, 1/4W J	EA	1
05-00077	R266, 375	Resistor, Carbon Film	15K Ohm, 1/4W J	EA	2
05-00078	R270	Resistor, Carbon Film	18K Ohm, 1/4W J	EA	1
05-00079	R206, 210, 249, 267	Resistor, Carbon Film	22K Ohm, 1/4W J	EA	4
05-00080	R271, 272	Resistor, Carbon Film	27K Ohm, 1/4W J	EA	2
05-00081	R219, 352, 378	Resistor, Carbon Film	33K Ohm, 1/4W J	EA	3
05-00082	R163, 166, 202, 220, 325	Resistor, Carbon Film	47K Ohm, 1/4W J	EA	8
05-00083	R227	Resistor, Carbon Film	56K Ohm, 1/4W J	EA	1
05-00084	R209, 303, 365	Resistor, Carbon Film	68K Ohm, 1/4W J	EA	3
05-00085	R302	Resistor, Carbon Film	75K Ohm, 1/4W J	EA	1
05-00086	R161, 165	Resistor, Carbon Film	82K Ohm, 1/4W J	EA	2
05-00087	R9, 113, 167, 169, 170	Resistor, Carbon Film	100K Ohm, 1/4W J	EA	19
05-00088	R351, 373	Resistor, Carbon Film	120K Ohm, 1/4W J	EA	2
05-00089	R201, 251, 361, 368	Resistor, Carbon Film	220K Ohm, 1/4W J	EA	4
05-00090	R72, 73, 347	Resistor, Carbon Film	470K Ohm, 1/4W J	EA	3
05-00091	R383	Resistor, Carbon Film	1.8M Ohm, 1/4W J	EA	1
05-00092	R301	Resistor, Carbon Film	2.2M Ohm, 1/4W J	EA	1
05-00093	R359	Resistor, Carbon Solide	4.7 Ohm, 1/4W J	EA	1
05-00094	R360	Resistor, Carbon Solide	47K Ohm, 1/4W J	EA	1
05-00095	R364	Resistor, Carbon Solide	100K Ohm, 1/4W J	EA	1
05-00096	R358	Resistor, Carbon Solide	1M Ohm, 1/4W J	EA	1
05-00097	R362, 363	Resistor, Carbon Solide	22M Ohm, 1/4W J	EA	2
05-00098	Jump Wire	Resistor, Carbon Film	0 Ohm, 1/4W J	EA	164
05-00010	C23, 28	Capacitor, Ceramic	1 pF, T 50V	EA	2
06-00011	C3, 13, 41, 93	Capacitor, Ceramic	2 PF, T 50V	EA	4
06-00012	C8, 46	Capacitor, Ceramic	5 pF, T 50V	EA	2
06-00013	C211	Capacitor, Ceramic	10 pF, T 50V	EA	1
06-00014	C244	Capacitor, Ceramic	12 pF, T 50V	EA	1
06-00015	C21, 222	Capacitor, Ceramic	15 pF, T 50V	EA	2
06-00016	C66, 68	Capacitor, Ceramic	18 pF, T 50V	EA	2
06-00017	C35	Capacitor, Ceramic	20 pF, T 50V	EA	1
06-00018	C9, 19, 47	Capacitor, Ceramic	22 pF, T 50V	EA	3
06-00019	C90, 91	Capacitor, Ceramic	33 pF, T 50V	EA	2
06-00020	C221	Capacitor, Ceramic	39 pF, T 50V	EA	1
06-00021	C201, 217, 227, 238	Capacitor, Ceramic	47 pF, T 50V	EA	4
06-00022	C228	Capacitor, Ceramic	50 pF, T 50V	EA	1
06-00023	C36, 29, 65, 67	Capacitor, Ceramic	101pF, T 50V	EA	4
06-00024	C243	Capacitor, Ceramic	151pF, T 50V	EA	1
06-00025	C226, 237, 210, 242	Capacitor, Ceramic	221pF, T 50V	EA	4
06-00026	C224, 225, 273	Capacitor, Ceramic	561pF, T 50V	EA	3
06-00027	C31, 60, 204, 218, 235,	Capacitor, Ceramic	103pF, 50V	EA	7
06-00028	C6, 24, 44, 62, 205, 206,	Capacitor, Ceramic	104pF, 50V	EA	15
06-00029	C330	Capacitor, Ceramic	0.5pF, T 500V	EA	1
06-00030	C203	Capacitor, Ceramic	5 pF, T 500V	EA	1
06-00031	C61, 64	Capacitor, Ceramic	47 pF, T 500V	EA	2
06-00032	C332, 334, 350, 351	Capacitor, Ceramic	102pF, 500V	EA	4
06-00033	C31, 26, 33, 34, 38, 240	Capacitor, Ceramic	103pF, 500V	EA	9
06-00034	C318~321, 232, 325, 338	Capacitor, Ceramic	103pF, 2KV	EA	7

## SECTION 6

## PARTS LIST

CODE	REF-NO	DESCRIPTION	SPECIFICATION	UNIT	Q'TY
06-00035	C219	Capacitor, Metalized	0.47 $\mu$ F, 200V	EA	1
06-00036	C220	Capacitor, Metalized	0.0047 $\mu$ F, 200V	EA	1
06-00037	C5, 43	Capacitor, Metalized	0.01 $\mu$ F, 630V	EA	2
06-00038	C95, 94	Capacitor, Metalized	0.022 $\mu$ F, 630V	EA	2
06-00039	C1, 39	Capacitor, Mica	33pF, 50V	EA	2
06-00040	C2, 40	Capacitor, Mica	221pF, 50V	EA	2
06-00041	C4, 42	Capacitor, Mica	152pF, 50V	EA	2
06-00042	C331, 206	Capacitor, Mylar	0.1 $\mu$ F, 50V	EA	2
06-00043	C27, 32, 390	Capacitor, Mylar	0.01 $\mu$ , 50V	EA	3
06-00044	C342, 236	Capacitor, Mylar	0.001 $\mu$ F, 50V	EA	2
06-00045	C246	Capacitor, Mylar	0.022 $\mu$ F, 50V	EA	1
06-00046	C209	Capacitor, Mylar	0.0022 $\mu$ F, 50V	EA	1
06-00047	C314	Capacitor, Mylar	0.047 $\mu$ F, 50V	EA	1
06-00048	C202, 220, 339	Capacitor, Mylar	0.0047 $\mu$ F, 50V	EA	3
06-00050	C15~17, 20, 25, 207, 212	Capacitor, Elect	1 $\mu$ F, 50V	EA	16
06-00051	C324	Capacitor, Elect	1 $\mu$ F, 250V	EA	1
06-00052	C305	Capacitor, Elect	10 $\mu$ F, 250V	EA	1
06-00053	C304, 301	Capacitor, Elect	100 $\mu$ , 160V	EA	2
06-00054	C10, 12, 48, 247~249	Capacitor, Elect	22 $\mu$ F, 16V	EA	6
06-00055	C250	Capacitor, Elect	220 $\mu$ F, 16V	EA	1
06-00056	C337	Capacitor, Elect	220 $\mu$ F, 50V	EA	1
06-00057	C307, 308, 310, 342	Capacitor, Elect	2200 $\mu$ F, 25V	EA	4
06-00058	C303	Capacitor, Elect	33 $\mu$ F, 250V	EA	1
06-00059	C251~253	Capacitor, Elect	330 $\mu$ F, 10V	EA	3
06-00060	C336	Capacitor, Elect	330 $\mu$ F, 25V	EA	1
06-00061	C7, 18, 22, 45, 49, 59, 63	Capacitor, Elect	4.7 $\mu$ F, 50V	EA	7
06-00062	C241	Capacitor, Elect	4.7 $\mu$ F, 250V	EA	1
06-00063	C208	Capacitor, Elect	47 $\mu$ F, 10V	EA	1
06-00070	TC1, 3, 5, 7, 9, 11	Capacitor, Trimmer	4P	EA	6
06-00071	TC2, 4, 6, 8, 10, 12, 23,	Capacitor, Trimmer	10P	EA	12
06-00072	TC14, 50	Capacitor, Trimmer	20P	EA	2
06-00080	L201, 390	Inductor	1mH	EA	2
06-00081	L10, 11, 202	Inductor	2.2 $\mu$ H	EA	3
06-00082	L301	Inductor	4.7 $\mu$ H	EA	1
06-00083	L1~4, 203	Inductor	47 $\mu$ H	EA	5
06-00084	L7, 8	Inductor	470M	EA	2
06-00085	L204, 205	Industor	820 $\mu$ H	EA	2
06-00090	NE301~304	Neon Lamp	NE38B	EA	4
06-00010	Verical	Switch, Rotary	PS-22BH 2-4-12	EA	2
06-00011	Horizon	Switch, Rotary	PS-22BH-2-4-21	EA	1
07-00012		Switch, Lever	SLR522	EA	1
07-00013		Switch, Lever	SLR523	EA	1
07-00014		Switch, Lever	SLR524	EA	2
07-00015		Switch, Slide	SSB423	EA	2
07-00017		Switch, Push/Push	1Key(024-1004-05)	EA	1
07-00018		Switch, Push/Push	3Pole	EA	1
07-00019		Switch, Push/Push	JPW-1101	EA	1
08-00010	CRT1	CRT	150BTB31A	EA	1
08-00011	TR1	Trans	Power	EA	1
08-00012	TR2	Trans	DC-TO-DC Convert	EA	1
08-00020	F1	Fuse	0.5A/250V 20mm	EA	1
08-00021	F302	Fuse	1A/250V 30mm	EA	1
08-00025		Socket	CRT	EA	1
08-00026		AC Inlet & Volt Select	42R-38	EA	1
08-00027		Fuse Holder	SN-5053	EA	2
08-00028		Ground Lug	275-1000-05	EA	1
08-00030		Mica Sheet		EA	3

## SECTION 6

## PARTS LIST

CODE	REF-NO	DESCRIPTION	SPECIFICATION	UNIT	Q'TY
08-00031		RT Bushing	Silica	EA	3
08-00032		Test Probe	CP007	EA	2
08-00033		Rotation Coil			1
08-00034		Cord	Power iIN 198-1002-05	EA	1
08-00035		Instruction Manual		EA	1
08-00036		Cable Tie	TY26M	EA	1
08-00037		Cable Tie	AN112	EA	16
08-00038		Metal Mount		EA	3
08-00010	PCB1	Verical PCB	L202-01-02		1
09-00011	PCB2	Horizon PCB	L202-02-02	EA	1
09-00012	PCB3	Power PCB	L202-03-02	EA	1
09-00013	PCB4	CRT PCB		EA	1
09-00030		Connector	BNC Receptacle	EA	4
09-00031		Connector	CAL Terminal	EA	1
09-00032	P1, 2, 5, 7, 8, 203~207	Connector PIN, Locking Type	5040-3A, Pitch 2.54mm	EA	16
09-00033	P208	Connector PIN, Locking Type	5040-4A, Pitch 2.54mm	EA	1
09-00034	P3	Connector PIN, Locking Type	5040-7A, Pitch 2.54mm	EA	1
09-00035	P4, 201	Connector PIN, Locking Type	5040-8A, Pitch 2.54mm	EA	2
09-00036	P307	Connector PIN, Locking Type	5040-9A, Pitch 2.54mm	EA	1
09-00037	P202, 304	Connector PIN, Locking Type	5040-9A, Pitch 2.54mm	EA	2
09-00038	P305	Connector PIN, Locking Type	5048-3P, Pitch 2.54mm	EA	1
09-00039	P6	Connector PIN, Locking Type	5048-3P, Pitch 2.54mm	EA	1
09-00040	P303	Connector PIN, Locking Type	5048-7P, Pitch 2.54mm	EA	1
09-00041	P301	Connector PIN, Locking Type	5275-09A, Pitch 3.96mm	EA	1
09-00045		Connector Housing	3P TR Sport	EA	6
09-00046		Connector Housing	2P Power Lamp	EA	1
09-00050		Connector, Housing Lock Type	3P, Read Wire Housing	EA	16
09-00051		Connector, Housing Lock Type	4P, Read Wire Housing	EA	1
09-00052		Connector, Housing Lock Type	7P, Read Wire Housing	EA	1
09-00053		Connector, Housing Lock Type	8P, Read Wire Housing	EA	2
09-00054		Connector, Housing Lock Type	9P, Read Wire Housing	EA	1
09-00055		Connector, Housing Lock Type	10P, Read Wire Housing	EA	2
09-00056		Connector, Housing Straight	3P, Read Wire Housing	EA	1
09-00057		Connector, Housing Straight	4P, Read Wire Housing	EA	1
09-00058		Connector, Housing Straight	7P, Read Wire Housing	EA	1
09-00060	L202-01		L170mm	EA	1
09-00061	L202-02		L170mm	EA	1
09-00062	L202-03		L200mm	EA	1
09-00063	L202-04		L160mm	EA	1
09-00064	L202-05		L390mm	EA	1
09-00065	L202-05		L315mm	EA	1
09-00066	L202-06		L220mm	EA	1
09-00067	L202-07		L290mm	EA	1
09-00068	L202-08		L280mm	EA	1
09-00069	L202-09		L150mm	EA	1
09-00070	L202-10		L200mm	EA	1
09-00071	L202-11		L245mm	EA	1
09-00072	L202-12		L115mm	EA	1
09-00073	L202-13		L230mm	EA	1
09-00074	L202-14		L350mm	EA	1
09-00075	L202-15		L250mm	EA	1
09-00076	L202-16		L140mm	EA	1
09-00077	L202-17		L400mm	EA	1
09-00078	L202-18		L255mm	EA	1
09-00079	L202-19		L210mm	EA	1
09-00080	L202-20		L130mm	EA	1
09-00081	L202-21		L155mm	EA	1
09-00082	L202-22		L80mm	EA	1

## SECTION 6

## PARTS LIST

CODE	REF-NO	DESCRIPTION	SPECIFICATION	UNIT	Q'TY
09-00083	L202-23		L30mm	EA	1
09-00084	L202-24		L60mm	EA	1
09-00085	L202-25		L65mm	EA	7
09-00086	L202-26		L130mm	EA	1
09-00087	L202-27		L70mm	EA	2
09-00088	L202-28		L40mm	EA	2
09-00089	L202-29		L60mm	EA	3
09-00090	L202-30		L60mm	EA	2
09-00091	L202-31		L35mm	EA	2
09-00095		Ring Terminal	3.2 Pi	EA	6
09-00096		Ring Terminal	6.0 Pi	EA	1

## SECTION 6

## PARTS LIST

CODE	REF-NO	DESCRIPTION	SPECIFICATION	UNIT	Q'TY
91-00001		Front Panel	ABS Resin	EA	1
91-00002		Rear Cover	ABS Resin	EA	1
91-00003		Bakelite Bar(A)	Bakelite	EA	2
91-00004		Bakelite Bar(B)	Bakelite	EA	1
91-00005		V/R Knob(L)	ABS Resin	EA	6
91-00006		V/R Knob(S)	ABS Resin	EA	3
91-00007		S/R Knob(L)	ABS Resin	EA	1
91-00008		S/R Knob(S)	ABS Resin	EA	2
91-00009		Lever S/W Knob	ABS Resin	EA	6
91-00010		Push S/W Knob	ABS Resin	EA	3
91-00011		Mould Foot	Polycarbonate	EA	2
91-00012		Mould Bearing	ABS Resin	EA	3
91-00013		Power Cord Rest	Polycarbonate	EA	4
91-00014		Cal Terminal	ABS+SPC	EA	1
92-00001		Joint Metal	BsBM Ni/Pi	EA	3
92-00002		Input Socket	BsBM Ni/Pi	EA	2
92-00003		Ground Terminal	Bs/BM Ni/Pi	EA	1
92-00004		S/R Knob Insert(L)	BsBM	EA	1
92-00005		S/R Knob Insert(S)	BsBM	EA	2
92-00006		V/R Knob Insert(L)	BsBM	EA	6
92-00007		V/R Knob Insert(S)	BsBM	EA	3
92-00008		S/W Pole	BsBM	EA	4
92-00009		S/W Bar	BSBM	EA	1
92-00010		PCB Pole	BSBM	EA	2
92-00011		Joint Metal	BSBM Ni/Pi	EA	1
93-00001		Top Case	Laminate 0.95t	EA	1
93-00002		Bottom Case	Laminate 0.95t	EA	1
93-00003		Rear Panel	SPC 1t Zn/Pi	EA	1
93-00004		Frame (A)	SPC 1.2t Zn/Pi	EA	4
93-00005		Frame (B)	SPC1.2t Zn/Pi	EA	1
93-00006		Frame (C)	SPC 1t Zn/Pi	EA	1
93-00007		V/R Bracket	SPC 1t Zn/Pi	EA	1
93-00008		Trans Bracket	SPC 2.0t Zn/Pi	EA	1
93-00009		CRT Band (A)	SPC 1.6t Zn/Pi	EA	1
93-00010		CRT Band (B)	SPC 1.6t Zn/Pi	EA	1
93-00011		Shield Plate (A)	SPTE 0.3t	EA	1
93-00012		Shield Plate (B)	SPTE 0.3t	EA	1
93-00013		Shield Plate (C)	SPTE 0.3t	EA	1
93-00014		Shield Plate (D)	SPTE 0.3t	EA	1
93-00015		Permalloy CRT Shield	SPTE 0.2t	EA	1
93-00016		Heat Sink	AL 1.5t	EA	6
93-00017		Tilt Stand	SWP Pi5 Ni/Pi	EA	1
93-00018		CRT MT Shield		EA	1
93-00019		Push S/W Shield		EA	1
93-00020		Shield Box	SPC 0.8t Ni/Pi	EA	1
93-00021		Shield Cover	SPC 0.8t Ni/Pi	EA	1
94-00001		Top Plate	Poly 0.3t	EA	1
94-00002		Top Plate	Poly 0.3t	EA	1
94-00003		Top Plate	Poly 0.3t	EA	1
95-00001		CRT Filter	Acryle 2t	EA	1
95-00002		CRT Cution	Rubber	EA	2
95-00003		Rubber Foot	Rubber	EA	6
95-00004		Handle Metal		EA	1
95-00005		Insulation Sheet	Vinyl	EA	1
96-00001		Machine Screw	PH(+) M3*6 ( )	EA	19
96-00002		Machine Screw	PH(+) M3*6Zn/Pi	EA	15
96-00003		Machine Screw	PH(+) M3*14Zn/Pi	EA	2
96-00004		Machine Screw	PH(+) M3*10Zn/Pi	EA	4

## SECTION 6

## PARTS LIST

CODE	REF-NO	DESCRIPTION	SPECIFICATION	UNIT	Q'TY
96-00005		Machine Screw	PH(+) M3*8Zn/P1	EA	8
96-00006		Machine Screw	PH(+) M4*30Zn/P1	EA	4
96-00007		Machine Screw	FH(+) M3*5Zn/P1	EA	6
96-00008		Machine Screw	FH(+) M3*15Zn/P1	EA	4
96-00009		Machine Screw	TH(+) M3*6Ni/P1	EA	5
96-00010		Machine Screw	OH(+) M4*12Ni/P1	EA	2
96-00011		Nut	M4	EA	8
96-00012		Nut	M3	EA	4
96-00013		Set Screw	M3	EA	27
96-00014		Spring Plate	Pi4	EA	6
96-00015		Bind Rivet		EA	28
96-00016		Snap Rivet		EA	4
97-00001		Poly Bag	Poly	EA	1
97-00002		Instruction Manual		EA	1
97-00003		Snow Box(R)		EA	1
97-00004		Snow Box(L)		EA	1
97-00005		Inner Box		EA	1
97-00006		Outer Box		EA	1
97-00007		Silica Gel	3g	EA	1

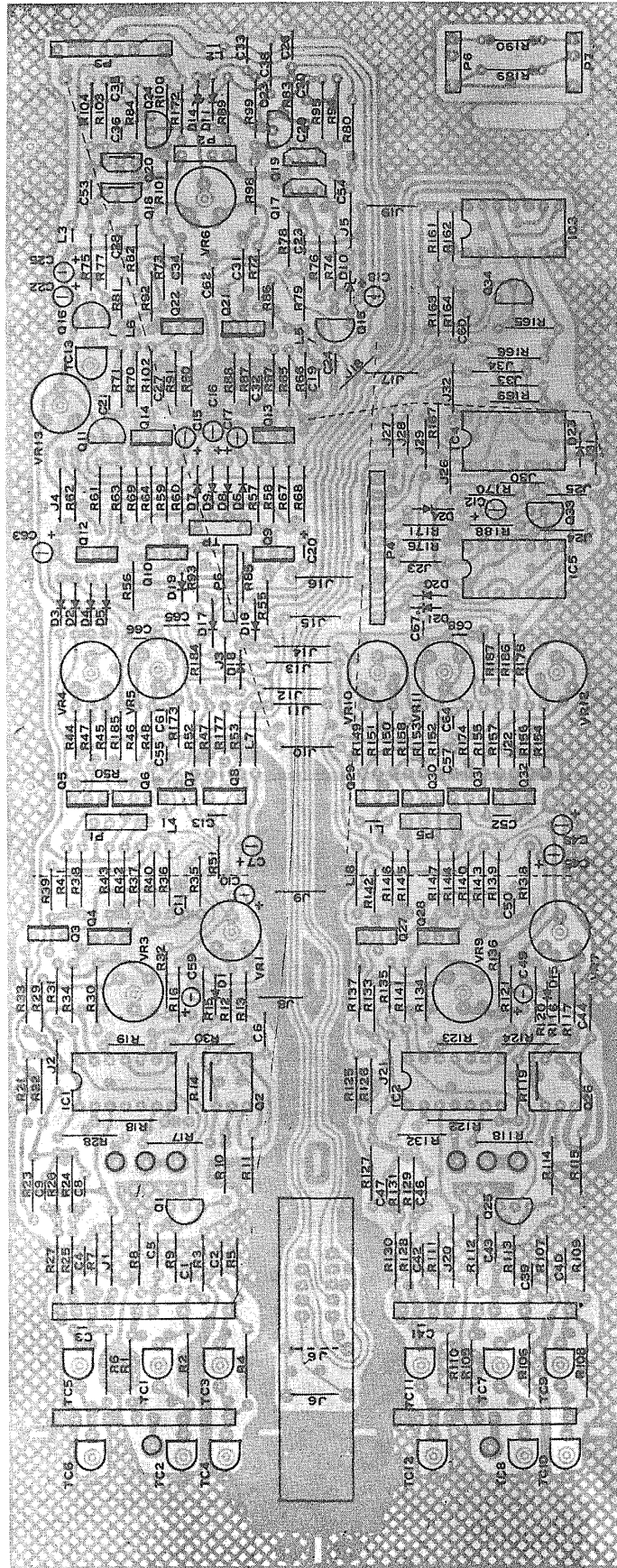

7-1 VERTICAL AMP UNIT



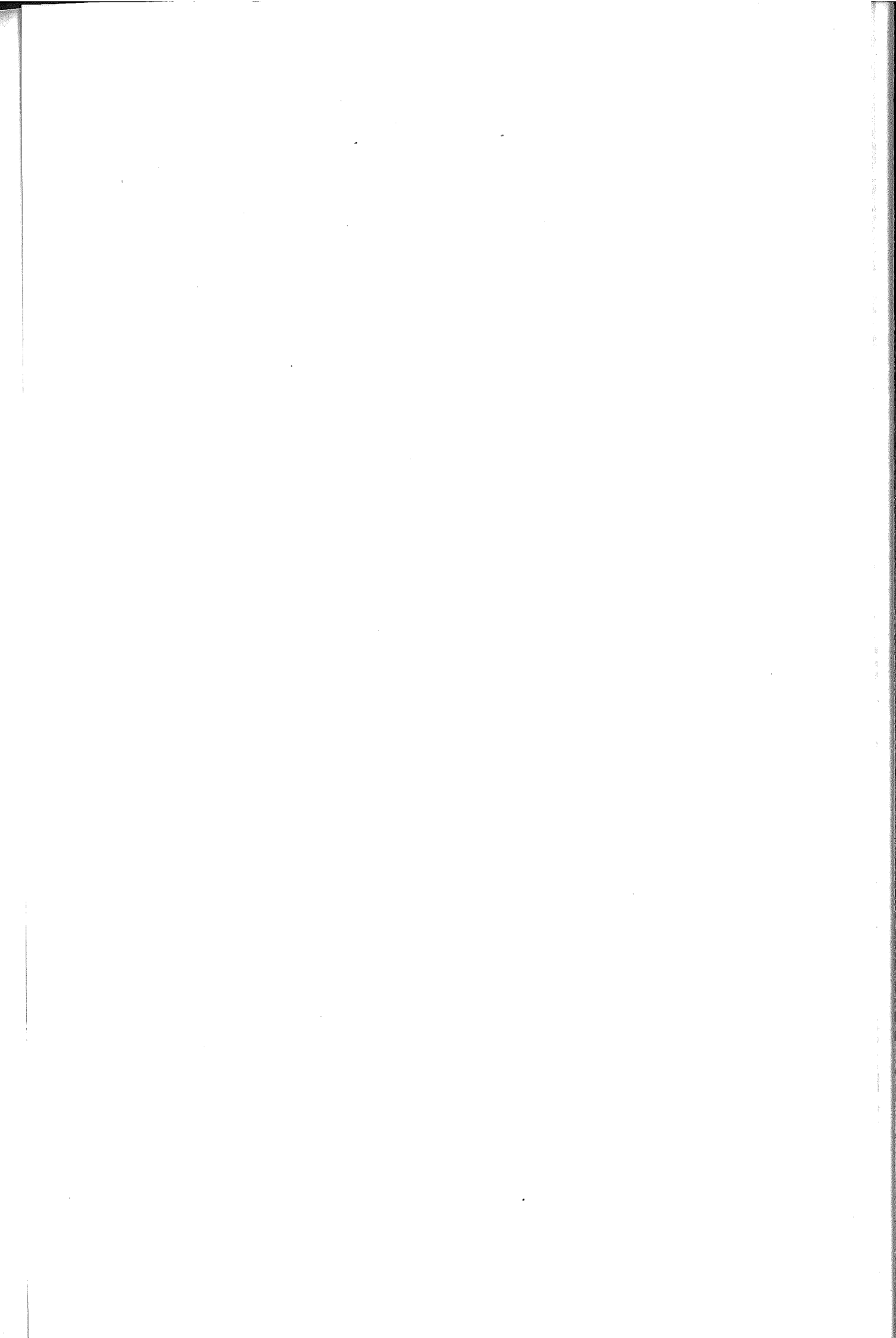

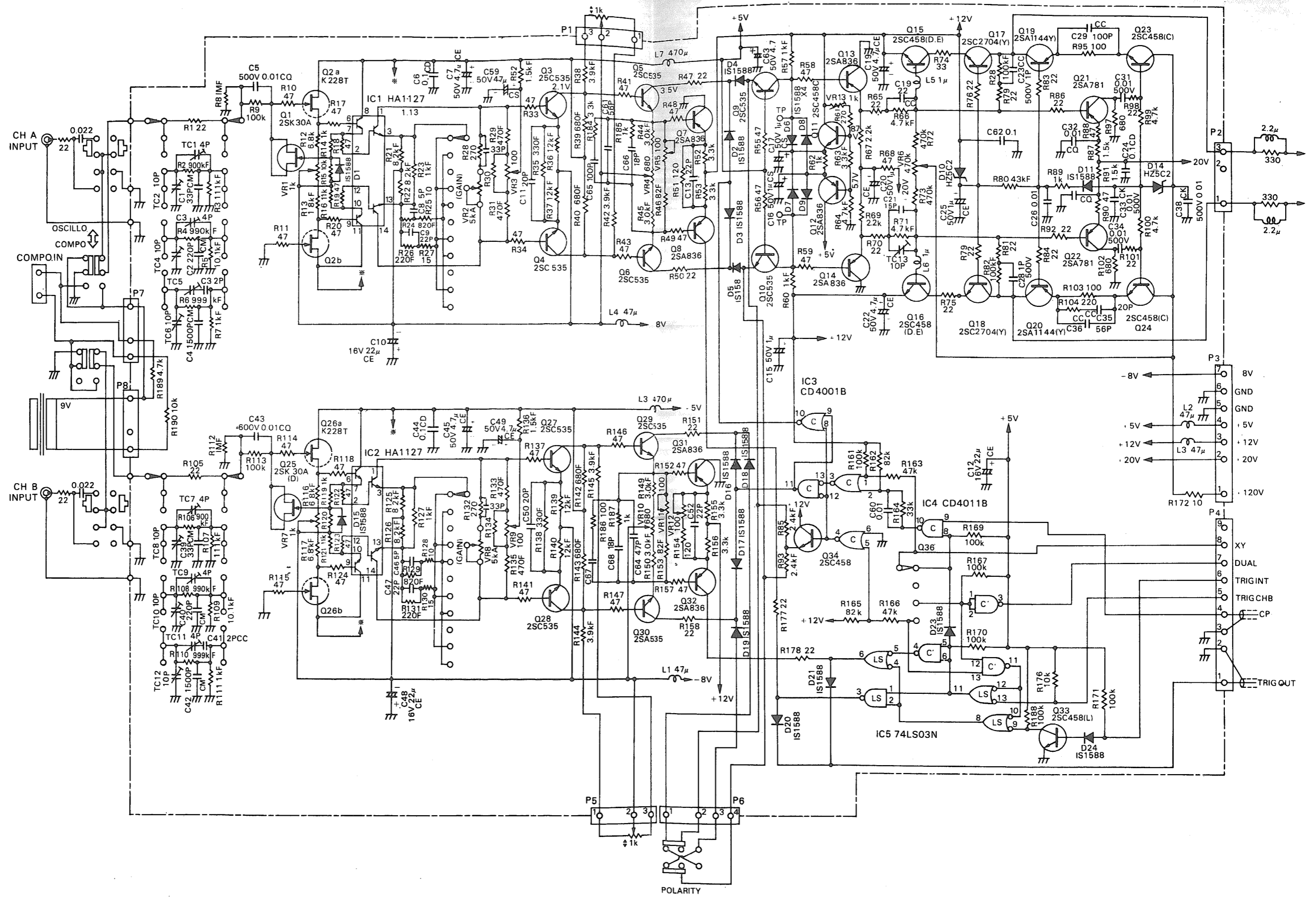

7-1-(1) VERTICAL AMP CIRCUIT DIAGRAM  
(290-1012-34)

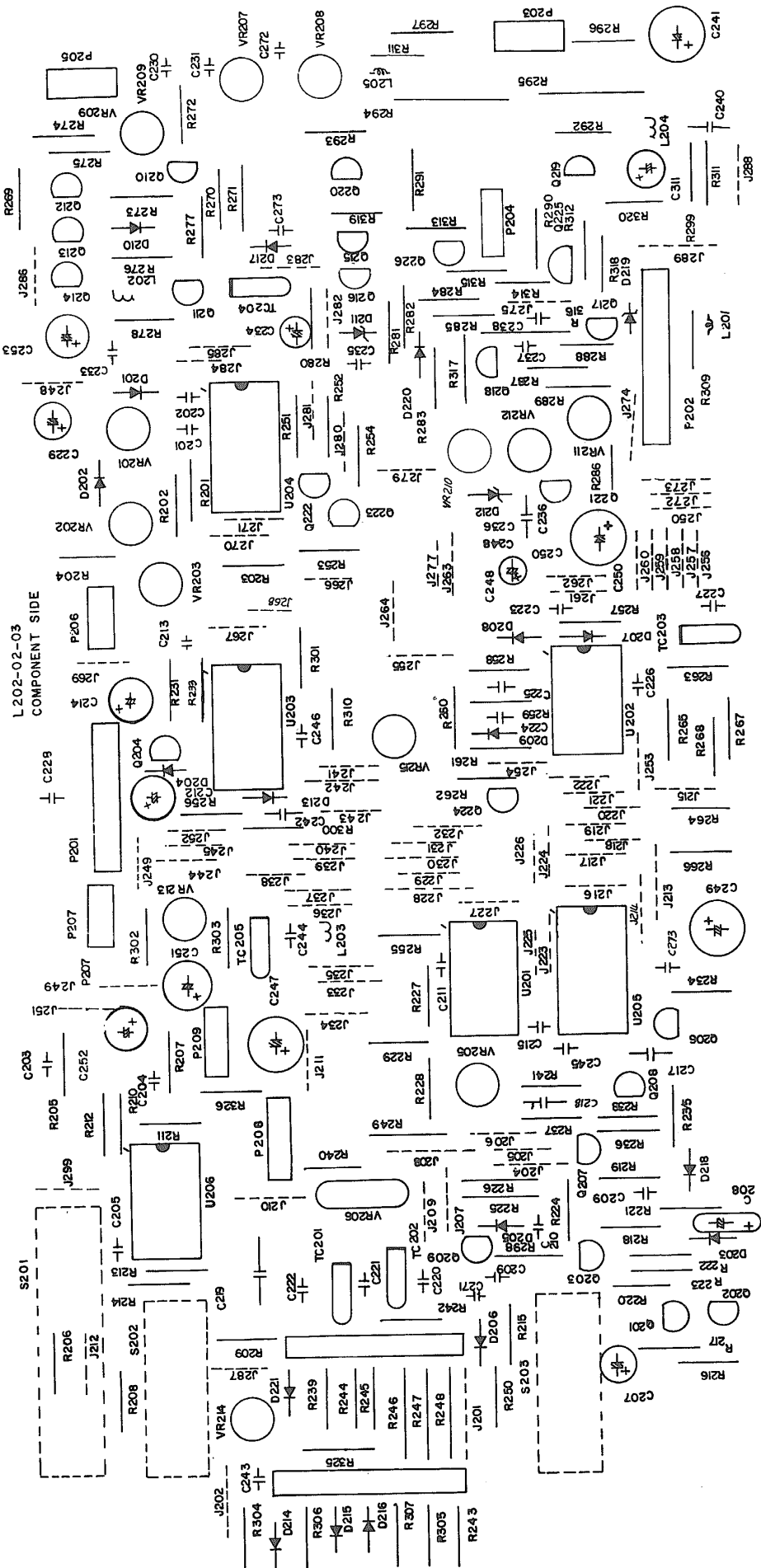

L202-02-03  
COMPONENT SIDE

7-2 HORIZONTAL/TIME BASE UNIT

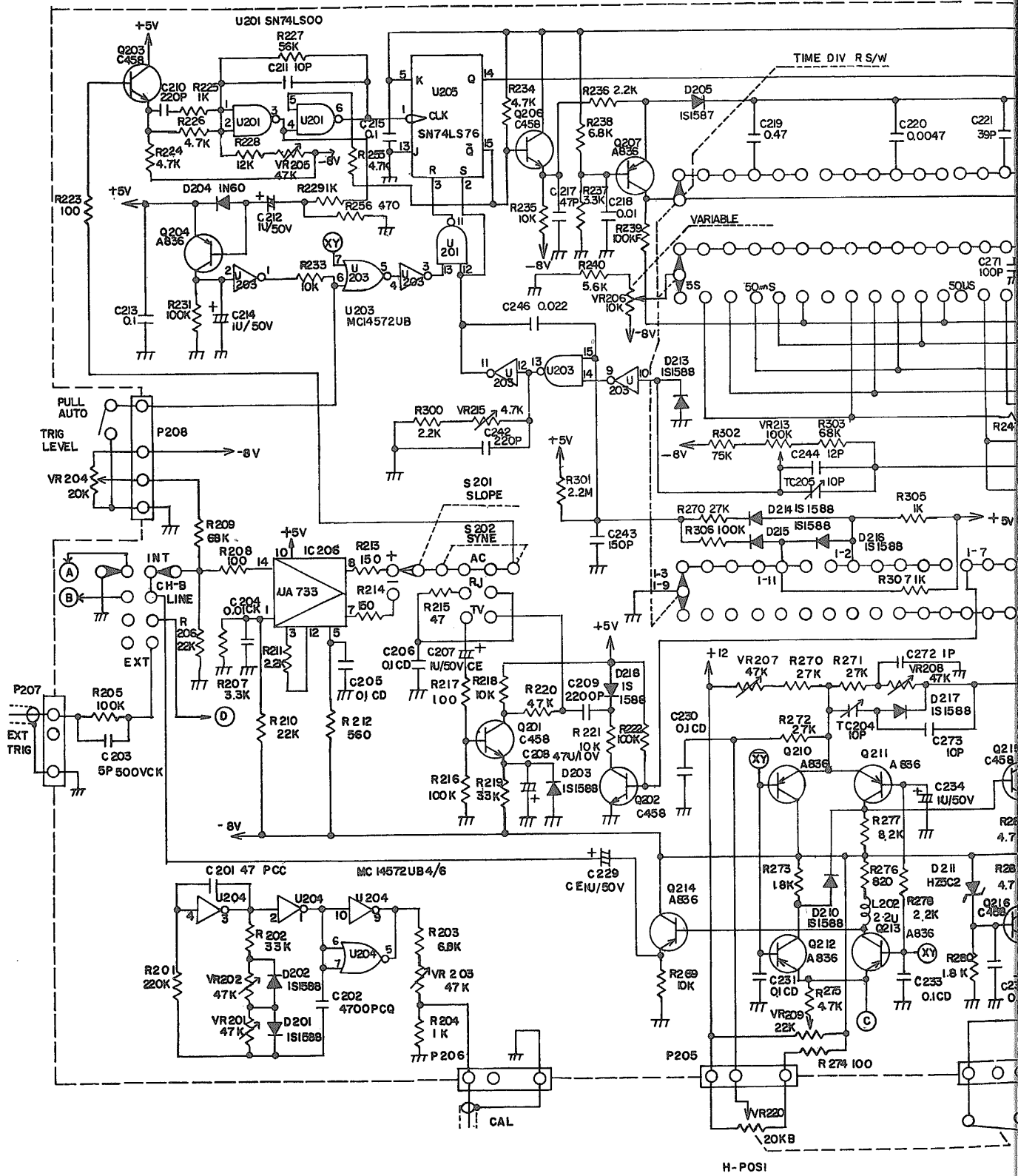

7-2-(1) HORIZONTAL/TIME BASE CIRCUIT DIAG

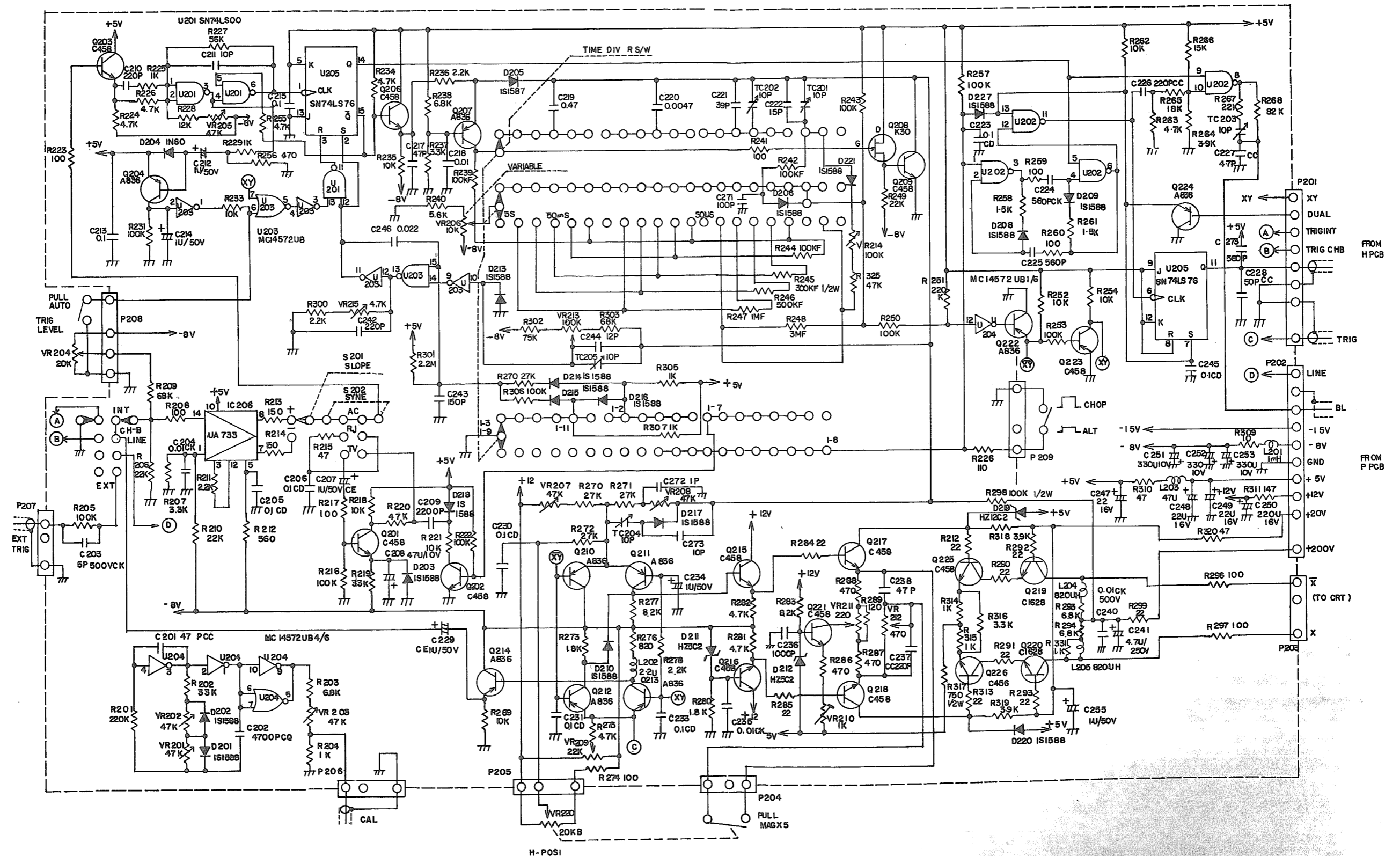

7-2-(1) HORIZONTAL/TIME BASE CIRCUIT DIAGRAM

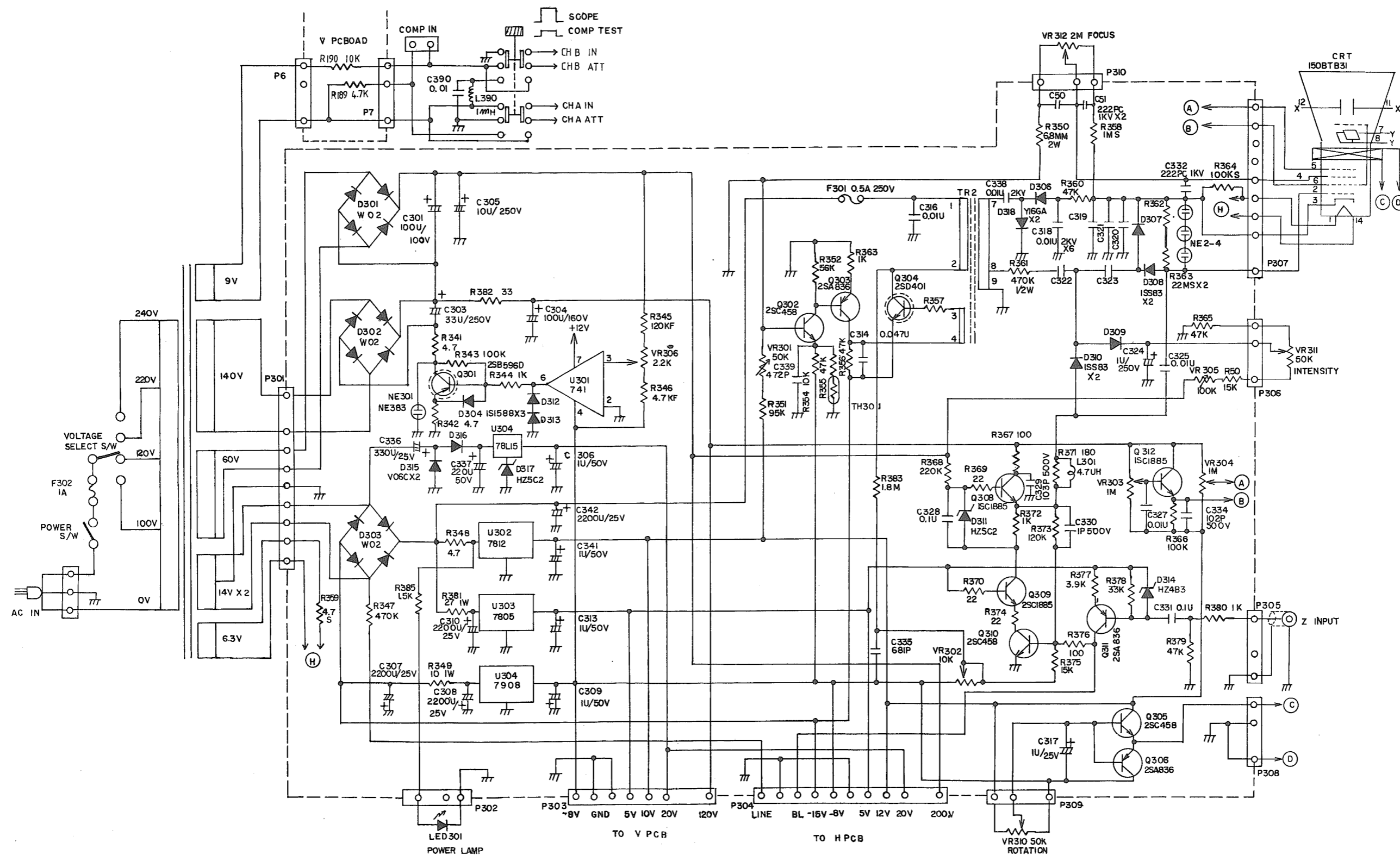

7-3 POWER SUPPLY CIRCUIT DIAGRAM

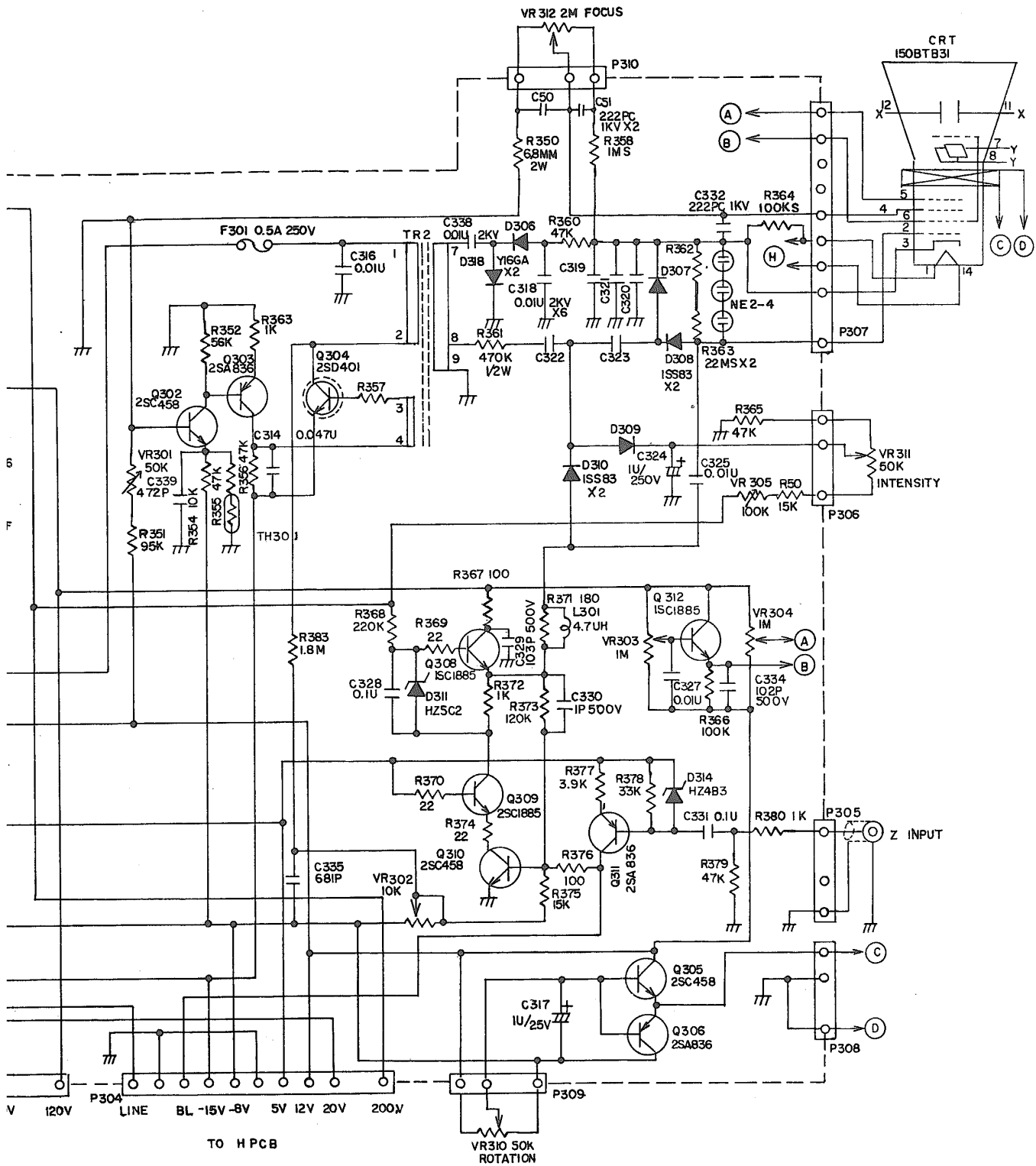

SUPPLY CIRCUIT DIAGRAM

